

Eleventh Edition

Intermediate Microeconomics and Its Application

Nicholson | Snyder



Intermediate Microeconomics and Its Application

NOT FOR SALE



SOUTH-WESTERN
CENGAGE Learning™

NOT FOR SALE

Intermediate Microeconomics and Its Application

11E

WALTER NICHOLSON
AMHERST COLLEGE

CHRISTOPHER SNYDER
DARTMOUTH COLLEGE



SOUTH-WESTERN
CENGAGE Learning™

Australia • Brazil • Japan • Korea • Mexico • Singapore • Spain • United Kingdom • United States



Intermediate Microeconomics, Eleventh Edition

Walter Nicholson and Christopher Snyder

Vice President of Editorial, Business: Jack W. Calhoun

Publisher: Melissa Acuna

Acquisitions Editor: Mike Roche

Developmental Editor: Susan Smart

Marketing Manager: John Carey

Marketing Coordinator: Suellen Ruttkay

Content Project Manager: Darrell Frye

Media Editor: Deepak Kumar

Frontlist Buyer, Manufacturing: Sandee Milewski

Compositor and Production Service: Cadmus Communications

Sr. Art Director: Michelle Kunkler

Internal Designer: Juli Cook

Cover Designer: Rose Alcorn

Cover Image: © George Clerk/iStockphotoPhotography Manager

© 2010, 2007 South-Western, Cengage Learning

ALL RIGHTS RESERVED. No part of this work covered by the copyright hereon may be reproduced or used in any form or by any means—graphic, electronic, or mechanical, including photocopying, recording, taping, Web distribution, information storage and retrieval systems, or in any other manner—except as may be permitted by the license terms herein.

For product information and technology assistance, contact us at **Cengage Learning Customer & Sales Support, 1-800-354-9706**

For permission to use material from this text or product, submit all requests online at www.cengage.com/permissions Further permissions questions can be emailed to permissionrequest@cengage.com

ExamView® is a registered trademark of elnstruction Corp. Windows is a registered trademark of the Microsoft Corporation used herein under license. Macintosh and Power Macintosh are registered trademarks of Apple Computer, Inc. used herein under license.

© 2008 Cengage Learning. All Rights Reserved.

Library of Congress Control Number: 2009931153
Instructors Edition ISBN 13: 978-1-4390-4805-4
Instructors Edition ISBN 10: 0-4390-4805-3
Instructors Edition with InfoApps ISBN 13: 978-1-4390-4765-1
Instructors Edition with InfoApps ISBN 10: 1-4390-4765-0

South-Western Cengage Learning

5191 Natorp Boulevard
Mason, OH 45040
USA

Cengage Learning products are represented in Canada by Nelson Education, Ltd.

For your course and learning solutions, visit www.cengage.com
Purchase any of our products at your local college store or at our preferred online store www.ichapters.com

TO ELIZABETH, SARAH, DAVID, SOPHIA, ABIGAIL,
NATHANIEL, AND CHRISTOPHER

Walter Nicholson

TO CLARE, TESS, AND MEG

Christopher Snyder



SOUTH-WESTERN
CENGAGE Learning™

About the Authors

Walter Nicholson Walter Nicholson is the Ward H. Patton Professor of Economics at Amherst College. He received a B.A. in mathematics from Williams College and a Ph.D. in economics from the Massachusetts Institute of Technology (MIT). Professor Nicholson's primary research interests are in the econometric analyses of labor market problems, including welfare, unemployment, and the impact of international trade. For many years, he has been Senior Fellow at Mathematica, Inc. and has served as an advisor to the U.S. and Canadian governments. He and his wife, Susan, live in Naples, Florida, and Amherst, Massachusetts.

Christopher Snyder Christopher Snyder is a Professor of Economics at Dartmouth College. He received his B.A. in economics and mathematics from Fordham University and his Ph.D. in economics from MIT. Before coming to Dartmouth in 2005, he taught at George Washington University for over a decade, and he has been a visiting professor at the University of Chicago and MIT. He is a past President of the Industrial Organization Society and Associate Editor of the *International Journal of Industrial Organization* and *Review of Industrial Organization*. His research covers various theoretical and empirical topics in industrial organization, contract theory, and law and economics.

Professor Snyder and his wife, Maura Doyle (who also teaches economics at Dartmouth), live within walking distance of campus in Hanover, New Hampshire, with their 3 daughters, ranging in age from 7 to 12.

Preface xxvii

PART 1 INTRODUCTION 1

CHAPTER 1 Economic Models 3
Appendix to Chapter 1: Mathematics Used in Microeconomics 26

PART 2 DEMAND 51

CHAPTER 2 Utility and Choice 53
CHAPTER 3 Demand Curves 87

PART 3 UNCERTAINTY AND STRATEGY 137

CHAPTER 4 Uncertainty 139
CHAPTER 5 Game Theory 175

PART 4 PRODUCTION, COSTS, AND SUPPLY 213

CHAPTER 6 Production 215
CHAPTER 7 Costs 243
CHAPTER 8 Profit Maximization and Supply 274

PART 5 PERFECT COMPETITION 301

CHAPTER 9 Perfect Competition in a Single Market 303
CHAPTER 10 General Equilibrium and Welfare 345

PART 6 MARKET POWER 375

CHAPTER 11 Monopoly 377
CHAPTER 12 Imperfect Competition 408

PART 7 INPUT MARKETS 449

CHAPTER 13 Pricing in Input Markets 451
Appendix to Chapter 13: Labor Supply 478
CHAPTER 14 Capital and Time 487
Appendix to Chapter 14: Compound Interest 509

BRIEF CONTENTS

PART 8 MARKET FAILURES 527

CHAPTER 15 Asymmetric Information 529

CHAPTER 16 Externalities and Public Goods 566

CHAPTER 17 Behavioral Economics 601

Glossary 637

Index 645



SOUTH-WESTERN
CENGAGE Learning™

NOT FOR SALE

PART 1	INTRODUCTION	1
CHAPTER 1	Economic Models	3
	What Is Microeconomics? 4	
	A Few Basic Principles 5	
	Uses of Microeconomics 7	
	Application 1.1: <i>Economics in the Natural World?</i> 8	
	Application 1.2: <i>Is It Worth Your Time to Be Here?</i> 9	
	The Basic Supply-Demand Model 10	
	<i>Adam Smith and the Invisible Hand</i> 10	
	Application 1.3: <i>Remaking Blockbuster</i> 11	
	<i>David Ricardo and Diminishing Returns</i> 13	
	<i>Marginalism and Marshall's Model of Supply and Demand</i> 13	
	<i>Market Equilibrium</i> 15	
	<i>Nonequilibrium Outcomes</i> 15	
	<i>Change in Market Equilibrium</i> 15	
	How Economists Verify Theoretical Models 16	
	<i>Testing Assumptions</i> 17	
	<i>Testing Predictions</i> 17	
	Application 1.4: <i>Economics According to Bono</i> 18	
	<i>The Positive-Normative Distinction</i> 19	
	Application 1.5: <i>Do Economists Ever Agree on Anything?</i> 20	
	Summary 21	
	Review Questions 21	
	Problems 22	
	Appendix to Chapter 1 <i>Mathematics Used in Microeconomics</i> 26	
	Functions of One Variable 26	
	Graphing Functions of One Variable 28	
	<i>Linear Functions: Intercepts and Slopes</i> 28	
	<i>Interpreting Slopes: An Example</i> 29	
	<i>Slopes and Units of Measurement</i> 30	
	<i>Changes in Slope</i> 31	
	<i>Nonlinear Functions</i> 32	
	<i>The Slope of a Nonlinear Function</i> 33	
	Application 1A.1: <i>How Does Zillow.com Do It?</i> 34	
	<i>Marginal and Average Effects</i> 35	
	<i>Calculus and Marginalism</i> 36	

Application 1A.2: <i>Can a “Flat” Tax Be Progressive?</i>	37
Functions of Two or More Variables	38
<i>Trade-Offs and Contour Lines: An Example</i>	38
<i>Contour Lines</i>	39
Simultaneous Equations	41
<i>Changing Solutions for Simultaneous Equations</i>	41
<i>Graphing Simultaneous Equations</i>	42
Empirical Microeconomics and Econometrics	43
<i>Random Influences</i>	43
Application 1A.3 <i>Can Supply and Demand Explain Changing World Oil Prices?</i>	44
<i>The Ceteris Paribus Assumption</i>	47
<i>Exogenous and Endogenous Variables</i>	47
<i>The Reduced Form</i>	48
Summary	49

PART 2	DEMAND	51
CHAPTER 2	Utility and Choice	53
	Utility	53
	<i>Ceteris Paribus Assumption</i>	54
	<i>Utility from Consuming Two Goods</i>	54
	<i>Measuring Utility</i>	55
	Assumptions about Preferences	55
	<i>Completeness</i>	55
	Application 2.1: <i>Can Money Buy Health and Happiness?</i>	56
	<i>Transitivity</i>	57
	<i>More Is Better: Defining an Economic “Good”</i>	57
	Voluntary Trades and Indifference Curves	58
	<i>Indifference Curves</i>	58
	Application 2.2: <i>Should Economists Care about How the Mind Works?</i>	59
	<i>Indifference Curves and the Marginal Rate of Substitution</i>	61
	<i>Diminishing Marginal Rate of Substitution</i>	61
	<i>Balance in Consumption</i>	62
	Indifference Curve Maps	63
	Illustrating Particular Preferences	64
	<i>A Useless Good</i>	64
	Application 2.3: <i>Product Positioning in Marketing</i>	65
	<i>An Economic Bad</i>	66
	<i>Perfect Substitutes</i>	67
	<i>Perfect Complements</i>	67
	Utility Maximization: An Initial Survey	67
	<i>Choices Are Constrained</i>	68
	<i>An Intuitive Illustration</i>	68
	Showing Utility Maximization on a Graph	69

<i>The Budget Constraint</i>	69
<i>Budget-Constraint Algebra</i>	70
<i>A Numerical Example</i>	71
<i>Utility Maximization</i>	71
Using the Model of Choice	73
Application 2.4: <i>Ticket Scalping</i>	74
<i>A Few Numerical Examples</i>	76
Application 2.5: <i>What's a Rich Uncle's Promise Worth?</i>	77
Generalizations	80
<i>Many Goods</i>	80
<i>Complicated Budget Constraints</i>	80
<i>Composite Goods</i>	81
Application 2.6: <i>Loyalty Programs</i>	82
Summary	83
Review Questions	83
Problems	85

CHAPTER 3

Demand Curves

87

Individual Demand Functions	87
<i>Homogeneity</i>	88
Changes in Income	89
<i>Normal Goods</i>	89
<i>Inferior Goods</i>	90
Changes in a Good's Price	90
<i>Substitution and Income Effects from a Fall in Price</i>	90
Application 3.1: <i>Engel's Law</i>	91
<i>Substitution Effect</i>	92
<i>Income Effect</i>	94
<i>The Effects Combined: A Numerical Example</i>	94
<i>The Importance of Substitution Effects</i>	95
<i>Substitution and Income Effects for Inferior Goods</i>	96
<i>Giffen's Paradox</i>	96
Application 3.2: <i>The Consumer Price Index and Its Biases</i>	98
An Application: The Lump-Sum Principle	100
<i>A Graphical Approach</i>	100
<i>Generalizations</i>	101
Changes in the Price of Another Good	101
Application 3.3: <i>Why Not Just Give the Poor Cash?</i>	102
<i>Substitutes and Complements</i>	104
Individual Demand Curves	105
<i>Shape of the Demand Curve</i>	105
Shifts in an Individual's Demand Curve	107
<i>Be Careful in Using Terminology</i>	108
Two Numerical Examples	109
<i>Perfect Complements</i>	109
<i>Some Substitutability</i>	109

	Consumer Surplus	110
	<i>Demand Curves and Consumer Surplus</i>	110
	<i>Consumer Surplus and Utility</i>	112
	Market Demand Curves	113
	<i>Construction of the Market Demand Curve</i>	113
	Application 3.4: <i>Valuing New Goods</i>	114
	<i>Shifts in the Market Demand Curve</i>	115
	<i>Numerical Examples</i>	116
	<i>A Simplified Notation</i>	116
	Elasticity	117
	<i>Use Percentage Changes</i>	117
	<i>Linking Percentages</i>	118
	Price Elasticity of Demand	118
	<i>Values of the Price Elasticity of Demand</i>	119
	<i>Price Elasticity and the Substitution Effect</i>	119
	<i>Price Elasticity and Time</i>	120
	<i>Price Elasticity and Total Expenditures</i>	120
	Application 3.5: <i>Brand Loyalty</i>	121
	Application 3.6: <i>Volatile Farm Prices</i>	123
	Demand Curves and Price Elasticity	124
	<i>Linear Demand Curves and Price Elasticity: A Numerical Example</i>	124
	<i>A Unit Elastic Curve</i>	126
	Application 3.7: <i>An Experiment in Health Insurance</i>	128
	Income Elasticity of Demand	129
	Cross-Price Elasticity of Demand	129
	Some Elasticity Estimates	130
	Summary	132
	Review Questions	132
	Problems	133
PART 3	UNCERTAINTY AND STRATEGY	137
CHAPTER 4	Uncertainty	139
	Probability and Expected Value	139
	Application 4.1: <i>Blackjack Systems</i>	141
	Risk Aversion	142
	<i>Diminishing Marginal Utility</i>	142
	<i>A Graphical Analysis of Risk Aversion</i>	142
	<i>Willingness to Pay to Avoid Risk</i>	144
	Methods for Reducing Risk and Uncertainty	144
	<i>Insurance</i>	145
	Application 4.2: <i>Deductibles in Insurance</i>	147
	<i>Diversification</i>	148
	Application 4.3: <i>Mutual Funds</i>	150
	<i>Flexibility</i>	151

Application 4.4: <i>Puts, Calls, and Black-Scholes</i>	155
<i>Information</i>	156
<i>Information Differences among Economic Actors</i>	158
Pricing of Risk in Financial Assets	159
Application 4.5: <i>The Energy Paradox</i>	160
<i>Investors' Market Options</i>	161
<i>Choices by Individual Investors</i>	162
Application 4.6: <i>The Equity Premium Puzzle</i>	163
Two-State Model	164
Summary	171
Review Questions	171
Problems	172

CHAPTER 5 Game Theory 175

Background	176
Basic Concepts	176
<i>Players</i>	176
<i>Strategies</i>	176
<i>Payoffs</i>	177
<i>Information</i>	177
Equilibrium	178
Illustrating Basic Concepts	178
<i>The Prisoners' Dilemma</i>	178
Application 5.1: <i>A Beautiful Mind</i>	179
<i>The Game in Normal Form</i>	180
<i>The Game in Extensive Form</i>	180
<i>Solving for the Nash Equilibrium</i>	181
<i>Dominant Strategies</i>	182
<i>Mixed Strategies</i>	184
<i>Matching Pennies</i>	184
<i>Solving for a Mixed-Strategy Nash Equilibrium</i>	185
<i>Interpretation of Random Strategies</i>	186
Application 5.2: <i>Mixed Strategies in Sports</i>	187
Multiple Equilibria	188
<i>Battle of the Sexes</i>	188
<i>Computing Mixed Strategies in the Battle of the Sexes</i>	189
<i>The Problem of Multiple Equilibria</i>	191
Sequential Games	192
<i>The Sequential Battle of the Sexes</i>	192
Application 5.3: <i>High-Definition Standards War</i>	194
<i>Subgame-Perfect Equilibrium</i>	197
<i>Backward Induction</i>	199
<i>Repeated Games</i>	200
Application 5.4: <i>Laboratory Experiments</i>	201
<i>Definite Time Horizon</i>	202
<i>Indefinite Time Horizon</i>	202

Continuous Actions	204
<i>Tragedy of the Commons</i>	204
<i>Shifting Equilibria</i>	205
N-Player Games	206
Incomplete Information	206
Application 5.5: <i>Terrorism</i>	207
Summary	208
Review Questions	208
Problems	209

PART 4	PRODUCTION, COSTS, AND SUPPLY	213
CHAPTER 6	Production	215
	Production Functions	215
	<i>Two-Input Production Function</i>	216
	Application 6.1: <i>Every Household Is a Firm</i>	217
	Marginal Product	218
	<i>Diminishing Marginal Product</i>	218
	<i>Marginal Product Curve</i>	218
	<i>Average Product</i>	219
	<i>Appraising the Marginal Product Concept</i>	220
	Isoquant Maps	220
	Application 6.2: <i>What Did U.S. Automakers Learn from the Japanese?</i>	221
	<i>Rate of Technical Substitution</i>	222
	<i>The RTS and Marginal Products</i>	223
	<i>Diminishing RTS</i>	224
	Returns to Scale	224
	<i>Adam Smith on Returns to Scale</i>	224
	Application 6.3: <i>Engineering and Economics</i>	225
	<i>A Precise Definition</i>	226
	<i>Graphic Illustrations</i>	226
	Application 6.4: <i>Returns to Scale in Beer and Wine</i>	228
	Input Substitution	229
	<i>Fixed-Proportions Production Function</i>	229
	<i>The Relevance of Input Substitutability</i>	230
	Changes in Technology	231
	<i>Technical Progress versus Input Substitution</i>	231
	<i>Multifactor Productivity</i>	232
	A Numerical Example of Production	233
	<i>The Production Function</i>	233
	Application 6.5: <i>Finding the Computer Revolution</i>	234
	<i>Average and Marginal Productivities</i>	235
	<i>The Isoquant Map</i>	235
	<i>Rate of Technical Substitution</i>	237
	<i>Technical Progress</i>	237

	Summary	238
	Review Questions	238
	Problems	239
CHAPTER 7	Costs	243
	Basic Concepts of Costs	244
	<i>Labor Costs</i>	244
	<i>Capital Costs</i>	245
	<i>Entrepreneurial Costs</i>	245
	Application 7.1: <i>Stranded Costs and Deregulation</i>	246
	<i>The Two-Input Case</i>	247
	<i>Economic Profits and Cost Minimization</i>	247
	Cost-Minimizing Input Choice	247
	<i>Graphic Presentation</i>	248
	<i>An Alternative Interpretation</i>	248
	<i>The Firm's Expansion Path</i>	250
	Cost Curves	250
	Application 7.2: <i>Is Social Responsibility Costly?</i>	251
	<i>Average and Marginal Costs</i>	253
	<i>Marginal Cost Curves</i>	254
	<i>Average Cost Curves</i>	255
	Distinction between the Short Run and the Long Run	256
	<i>Holding Capital Input Constant</i>	257
	<i>Types of Short-Run Costs</i>	257
	Application 7.3: <i>Findings on Firms' Average Costs</i>	258
	<i>Input Inflexibility and Cost Minimization</i>	260
	Per-Unit Short-Run Cost Curves	260
	Shifts in Cost Curves	262
	<i>Changes in Input Prices</i>	262
	Application 7.4: <i>Congestion Costs</i>	263
	<i>Technological Innovation</i>	264
	<i>Economies of Scope</i>	264
	A Numerical Example	264
	Application 7.5: <i>Are Economies of Scope in Banking a Bad Thing?</i>	265
	<i>Long-Run Cost Curves</i>	266
	<i>Short-Run Costs</i>	266
	Summary	269
	Review Questions	270
	Problems	271
CHAPTER 8	Profit Maximization and Supply	274
	The Nature of Firms	274
	<i>Why Firms Exist</i>	274
	<i>Contracts within Firms</i>	275
	<i>Contract Incentives</i>	276
	<i>Firms' Goals and Profit Maximization</i>	276

Profit Maximization	277	
<i>Marginalism</i>	277	
<i>The Output Decision</i>	277	
Application 8.1: <i>Corporate Profits Taxes and the Leveraged Buyout Craze</i>	278	
<i>The Marginal Revenue/Marginal Cost Rule</i>	279	
<i>Marginalism in Input Choices</i>	280	
Marginal Revenue	281	
<i>Marginal Revenue for a Downward-Sloping Demand Curve</i>	281	
<i>A Numerical Example</i>	281	
<i>Marginal Revenue and Price Elasticity</i>	282	
Marginal Revenue Curve	285	
<i>Numerical Example Revisited</i>	285	
Application 8.2: <i>Maximizing Profits from Bagels and Catalog Sales</i>	286	
<i>Shifts in Demand and Marginal Revenue Curves</i>	288	
Supply Decisions of a Price-Taking Firm	288	
<i>Price-Taking Behavior</i>	288	
Application 8.3: <i>How Did Airlines Respond to Deregulation?</i>	289	
<i>Short-Run Profit Maximization</i>	290	
Application 8.4: <i>Price-Taking Behavior</i>	291	
<i>Showing Profits</i>	292	
<i>The Firm's Short-Run Supply Curve</i>	292	
<i>The Shutdown Decision</i>	293	
Summary	294	
Application 8.5: <i>Why Is Drilling for Crude Oil Such a Boom-or-Bust Business?</i>	295	
Review Questions	296	
Problems	297	
PART 5	PERFECT COMPETITION	301
CHAPTER 9	Perfect Competition in a Single Market	303
	Timing of a Supply Response	303
	Pricing in the Very Short Run	304
	<i>Shifts in Demand: Price as a Rationing Device</i>	304
	<i>Applicability of the Very Short-Run Model</i>	305
	Short-Run Supply	305
	Application 9.1: <i>Internet Auctions</i>	306
	<i>Construction of a Short-Run Supply Curve</i>	307
	Short-Run Price Determination	308
	<i>Functions of the Equilibrium Price</i>	308
	<i>Effect of an Increase in Market Demand</i>	309
	Shifts in Supply and Demand Curves	310
	<i>Short-Run Supply Elasticity</i>	310
	<i>Shifts in Supply Curves and the Importance of the Shape of the Demand Curve</i>	311

	<i>Shifts in Demand Curves and the Importance of the Shape of the Supply Curve</i>	312
	<i>A Numerical Illustration</i>	313
	<i>Application 9.2: Ethanol Subsidies in the United States and Brazil</i>	314
	The Long Run	316
	<i>Equilibrium Conditions</i>	316
	<i>Profit Maximization</i>	317
	<i>Entry and Exit</i>	317
	<i>Long-Run Equilibrium</i>	317
	Long-Run Supply: The Constant Cost Case	318
	<i>Market Equilibrium</i>	318
	<i>A Shift in Demand</i>	319
	<i>Long-Run Supply Curve</i>	319
	Shape of the Long-Run Supply Curve	319
	<i>The Increasing Cost Case</i>	320
	<i>Long-Run Supply Elasticity</i>	321
	<i>Estimating Long-Run Elasticities of Supply</i>	321
	<i>Can Supply Curves Be Negatively Sloped?</i>	322
	<i>Application 9.3: How Do Network Externalities Affect Supply Curves?</i>	323
	Consumer and Producer Surplus	324
	<i>Short-Run Producer Surplus</i>	325
	<i>Long-Run Producer Surplus</i>	325
	<i>Ricardian Rent</i>	325
	<i>Economic Efficiency</i>	326
	<i>Application 9.4: Does Buying Things on the Internet Improve Welfare?</i>	328
	<i>A Numerical Illustration</i>	329
	Some Supply-Demand Applications	330
	<i>Tax Incidence</i>	330
	<i>Long-Run Incidence with Increasing Costs</i>	332
	<i>Application 9.5: The Tobacco “Settlement” Is Just a Tax</i>	334
	<i>A Numerical Illustration</i>	335
	<i>Trade Restrictions</i>	336
	<i>Application 9.6: The Saga of Steel Tariffs</i>	339
	Summary	340
	Review Questions	340
	Problems	341
CHAPTER 10	General Equilibrium and Welfare	345
	A Perfectly Competitive Price System	346
	Why Is General Equilibrium Necessary?	346
	<i>Disturbing the Equilibrium</i>	346
	<i>Reestablishing Equilibrium</i>	348
	A Simple General Equilibrium Model	348

Application 10.1: <i>Modeling Excess Burden with a Computer</i>	349
The Efficiency of Perfect Competition	351
<i>Some Numerical Examples</i>	353
<i>Prices, Efficiency, and Laissez-Faire Economics</i>	355
Why Markets Fail to Achieve Economic Efficiency	356
<i>Imperfect Competition</i>	356
<i>Externalities</i>	356
<i>Public Goods</i>	356
<i>Imperfect Information</i>	357
Efficiency and Equity	357
Application 10.2: <i>Gains from Free Trade and the NAFTA and CAFTA Debates</i>	358
<i>Defining and Achieving Equity</i>	360
<i>Equity and Competitive Markets</i>	360
The Edgeworth Box Diagram for Exchange	360
<i>Mutually Beneficial Trades</i>	361
<i>Efficiency in Exchange</i>	361
<i>Contract Curve</i>	362
<i>Efficiency and Equity</i>	363
<i>Equity and Efficiency with Production</i>	363
Money in General Equilibrium Models	364
Application 10.3: <i>The Second Theorem of Welfare Economics</i>	365
<i>Nature and Function of Money</i>	366
<i>Money as the Accounting Standard</i>	366
<i>Commodity Money</i>	367
<i>Fiat Money and the Monetary Veil</i>	367
Application 10.4: <i>Commodity Money</i>	368
Summary	369
Review Questions	370
Problems	370

PART 6	MARKET POWER	375
CHAPTER 11	Monopoly	377
	Causes of Monopoly	377
	<i>Technical Barriers to Entry</i>	377
	<i>Legal Barriers to Entry</i>	378
	Application 11.1: <i>Should You Need a License to Shampoo a Dog?</i>	379
	Profit Maximization	380
	<i>A Graphic Treatment</i>	380
	<i>Monopoly Supply Curve?</i>	381
	<i>Monopoly Profits</i>	381
	What's Wrong with Monopoly?	382
	<i>Deadweight Loss</i>	383
	<i>Redistribution from Consumers to the Firm</i>	384

Application 11.2: <i>Who Makes Money at Casinos?</i>	385
<i>A Numerical Illustration of Deadweight Loss</i>	386
<i>Buying a Monopoly Position</i>	388
Price Discrimination	388
<i>Perfect Price Discrimination</i>	389
<i>Market Separation</i>	390
Application 11.3: <i>Financial Aid at Private Colleges</i>	391
<i>Nonlinear Pricing</i>	393
Application 11.4: <i>Mickey Mouse Monopoly</i>	396
Application 11.5: <i>Bundling of Cable and Satellite Television Offerings</i>	398
<i>Durability</i>	399
Natural Monopolies	400
<i>Marginal Cost Pricing and the Natural Monopoly Dilemma</i>	400
<i>Two-Tier Pricing Systems</i>	402
<i>Rate of Return Regulation</i>	402
Application 11.6: <i>Does Anyone Understand Telephone Pricing?</i>	403
Summary	404
Review Questions	404
Problems	405
CHAPTER 12 Imperfect Competition	408
Overview: Pricing of Homogeneous Goods	409
<i>Competitive Outcome</i>	409
<i>Perfect Cartel Outcome</i>	409
<i>Other Possibilities</i>	410
Cournot Model	411
Application 12.1: <i>Measuring Oligopoly Power</i>	412
<i>Nash Equilibrium in the Cournot Model</i>	414
<i>Comparisons and Antitrust Considerations</i>	415
<i>Generalizations</i>	416
Application 12.2: <i>Cournot in California</i>	417
Bertrand Model	418
<i>Nash Equilibrium in the Bertrand Model</i>	418
Bertrand Paradox	419
<i>Capacity Choice and Cournot Equilibrium</i>	419
<i>Comparing the Bertrand and Cournot Results</i>	420
Product Differentiation	421
Market Definition	421
Bertrand Model with Differentiated Products	421
Product Selection	422
Application 12.3: <i>Competition on the Beach</i>	423
Search Costs	425
Advertising	426
Application 12.4: <i>Searching the Internet</i>	427
Tacit Collusion	428

	Application 12.5: <i>The Great Electrical Equipment Conspiracy</i>	429
	<i>Finite Time Horizon</i>	430
	<i>Indefinite Time Horizon</i>	430
	<i>Generalizations and Limitations</i>	431
	Entry and Exit	432
	<i>Sunk Costs and Commitment</i>	433
	<i>First-Mover Advantages</i>	433
	<i>Entry Deterrence</i>	434
	<i>A Numerical Example</i>	435
	<i>Limit Pricing</i>	436
	<i>Asymmetric Information</i>	437
	<i>Predatory Pricing</i>	438
	Application 12.6: <i>The Standard Oil Legend</i>	439
	Other Models of Imperfect Competition	440
	<i>Price Leadership</i>	440
	<i>Monopolistic Competition</i>	442
	Barriers to Entry	443
	Summary	444
	Review Questions	445
	Problems	445
PART 7	INPUT MARKETS	449
CHAPTER 13	Pricing in Input Markets	451
	Marginal Productivity Theory of Input Demand	451
	<i>Profit-Maximizing Behavior and the Hiring of Inputs</i>	452
	<i>Price-Taking Behavior</i>	452
	<i>Marginal Revenue Product</i>	452
	<i>A Special Case: Marginal Value Product</i>	453
	Responses to Changes in Input Prices	454
	<i>Single-Variable Input Case</i>	454
	<i>A Numerical Example</i>	454
	Application 13.1: <i>Jet Fuel and Hybrid Seeds</i>	455
	<i>Two-Variable Input Case</i>	457
	<i>Substitution Effect</i>	457
	<i>Output Effect</i>	457
	<i>Summary of Firm's Demand for Labor</i>	458
	Responsiveness of Input Demand to Input Price Changes	459
	<i>Ease of Substitution</i>	459
	<i>Costs and the Output Effect</i>	459
	<i>Input Supply</i>	460
	Application 13.2: <i>Controversy over the Minimum Wage</i>	461
	<i>Labor Supply and Wages</i>	462
	Equilibrium Input Price Determination	462
	<i>Shifts in Demand and Supply</i>	463
	Monopsony	464
	<i>Marginal Expense</i>	464

Application 13.3: <i>Why Is Wage Inequality Increasing?</i>	465
<i>A Numerical Illustration</i>	466
<i>Monopsonist's Input Choice</i>	467
<i>A Graphical Demonstration</i>	468
<i>Numerical Example Revisited</i>	469
<i>Monopsonists and Resource Allocation</i>	469
<i>Causes of Monopsony</i>	470
<i>Bilateral Monopoly</i>	470
Application 13.4: <i>Monopsony in the Market for Sports Stars</i>	471
Application 13.5: <i>Superstars</i>	473
Summary	474
Review Questions	474
Problems	475
Appendix to Chapter 13 Labor Supply	478
Allocation of Time	478
<i>A Simple Model of Time Use</i>	478
<i>The Opportunity Cost of Leisure</i>	480
<i>Utility Maximization</i>	480
Application 13A.1: <i>The Opportunity Cost of Time</i>	481
Income and Substitution Effects of a Change in the Real Wage Rate	482
<i>A Graphical Analysis</i>	482
Market Supply Curve for Labor	484
Application 13A.2: <i>The Earned Income Tax Credit</i>	485
Summary	486
CHAPTER 14 Capital and Time	487
Time Periods and the Flow of Economic Transactions	487
Individual Savings: The Supply of Loans	488
<i>Two-Period Model of Saving</i>	488
<i>A Graphical Analysis</i>	489
<i>A Numerical Example</i>	490
<i>Substitution and Income Effects of a Change in r</i>	490
Firms' Demand for Capital and Loans	492
<i>Rental Rates and Interest Rates</i>	492
Application 14.1: <i>Do We Need Tax Breaks for Savers?</i>	493
<i>Ownership of Capital Equipment</i>	494
Determination of the Real Interest Rate	494
Application 14.2: <i>Do Taxes Affect Investment?</i>	495
<i>Changes in the Real Interest Rate</i>	496
Application 14.3: <i>Usury</i>	497
Present Discounted Value	498
<i>Single-Period Discounting</i>	498
<i>Multiperiod Discounting</i>	498
Application 14.4: <i>The Real Interest Rate Paradox</i>	499
<i>Present Value and Economic Decisions</i>	500
Pricing of Exhaustible Resources	501
<i>Scarcity Costs</i>	501

Application 14.5: *Discounting Cash Flows and Derivative Securities* 502

The Size of Scarcity Costs 503

Application 14.6: *Are Any Resources Scarce?* 504

Time Pattern of Resource Prices 505

Summary 505

Review Questions 506

Problems 507

Appendix to Chapter 14 Compound Interest 509

Interest 509

Compound Interest 509

Interest for One Year 509

Interest for Two Years 510

Interest for Three Years 510

A General Formula 510

Compounding with Any Dollar Amount 511

Present Discounted Value 512

An Algebraic Definition 512

Application 14A.1: *Compound Interest Gone Berserk* 513

General PDV Formulas 514

Discounting Payment Streams 515

An Algebraic Presentation 515

Application 14A.2: *Zero-Coupon Bonds* 516

Perpetual Payments 517

Varying Payment Streams 518

Calculating Yields 519

Reading Bond Tables 519

Frequency of Compounding 520

Semiannual Compounding 520

A General Treatment 521

Real versus Nominal Interest Rates 521

Application 14A.3: *Continuous Compounding* 522

The Present Discounted Value Approach to Investment

Decisions 523

Present Discounted Value and the Rental Rate 524

Summary 525

PART 8 MARKET FAILURES 527

CHAPTER 15 Asymmetric Information 529

Principal-Agent Model 530

Application 15.1: *Principals and Agents in Franchising and Medicine* 531

Moral Hazard: Manager's Private Information about Effort 532

Full Information About Effort 532

Incentive Schemes When Effort Is Unobservable 534

	<i>Problems with High-Powered Incentives</i>	536
	Application 15.2: <i>The Good and Bad Effects of Stock Options</i>	537
	<i>Substitutes for High-Powered Incentives</i>	539
	<i>Manager's Participation</i>	539
	<i>Summing Up</i>	540
	Adverse Selection: Consumer's Private Information about Valuation	540
	Application 15.3: <i>Moral Hazard in the Financial Crisis</i>	541
	<i>One Consumer Type</i>	542
	<i>Two Consumer Types, Full Information</i>	544
	<i>Two Consumer Types, Asymmetric Information</i>	544
	<i>Examples</i>	547
	<i>Agent's Participation</i>	548
	<i>Adverse Selection Leads to Inefficiency</i>	548
	Warranty and Insurance Contracts	548
	Application 15.4: <i>Adverse Selection in Insurance</i>	550
	Asymmetric Information in Competitive Markets	551
	<i>Moral Hazard with Several Agents</i>	551
	<i>Auctions and Adverse Selection</i>	551
	<i>The Market for Lemons</i>	554
	Signaling	555
	<i>Spence Education Model</i>	555
	Application 15.5: <i>Looking for Lemons</i>	556
	<i>Separating Equilibrium</i>	558
	<i>Pooling Equilibria</i>	559
	<i>Predatory Pricing and Other Signaling Games</i>	560
	<i>Inefficiency in Signaling Games</i>	561
	Summary	561
	Review Questions	562
	Problems	563
CHAPTER 16	Externalities and Public Goods	566
	Defining Externalities	566
	<i>Externalities between Firms</i>	567
	<i>Externalities between Firms and People</i>	567
	<i>Externalities between People</i>	568
	<i>Reciprocal Nature of Externalities</i>	568
	Externalities and Allocational Efficiency	568
	Application 16.1: <i>Secondhand Smoke</i>	569
	<i>A Graphical Demonstration</i>	570
	Property Rights, Bargaining, and the Coase Theorem	571
	<i>Costless Bargaining and Competitive Markets</i>	572
	<i>Ownership by the Polluting Firm</i>	572
	<i>Ownership by the Injured Firm</i>	572
	<i>The Coase Theorem</i>	573
	<i>Distributional Effects</i>	573

Application 16.2: <i>Property Rights and Nature</i>	574
<i>The Role of Transaction Costs</i>	575
Externalities with High Transactions Costs	575
<i>Legal Redress</i>	575
<i>Taxation</i>	576
<i>Regulation of Externalities</i>	576
Application 16.3: <i>Product Liability</i>	577
<i>Optimal Regulation</i>	578
<i>Fees, Permits, and Direct Controls</i>	578
Application 16.4: <i>Power Plant Emissions and the Global Warming Debate</i>	580
Public Goods	582
<i>Attributes of Public Goods</i>	582
<i>Nonexclusivity</i>	582
<i>Nonrivalry</i>	583
<i>Categories of Public Goods</i>	583
Public Goods and Market Failure	584
Application 16.5: <i>Ideas as Public Goods</i>	585
<i>A Graphical Demonstration</i>	586
Solutions to the Public Goods Problem	587
<i>Nash Equilibrium and Underproduction</i>	587
<i>Compulsory Taxation</i>	588
<i>The Lindahl Equilibrium</i>	589
Revealing the Demand for Public Goods	589
Application 16.6: <i>Fund Raising on Public Broadcasting</i>	590
<i>Local Public Goods</i>	591
Voting for Public Goods	591
<i>Majority Rule</i>	591
Application 16.7: <i>Referenda on Limiting Public Spending</i>	592
<i>The Paradox of Voting</i>	593
<i>Single-Peaked Preferences and the Median Voter Theorem</i>	594
<i>Voting and Efficient Resource Allocation</i>	595
<i>Representative Government and Bureaucracies</i>	595
Summary	596
Review Questions	597
Problems	597

CHAPTER 17	Behavioral Economics	601
	Should We Abandon Neoclassical Economics?	602
	Limits to Human Decision Making: An Overview	603
	Limited Cognitive Power	604
	<i>Uncertainty</i>	605
	Application 17.1: <i>Household Finance</i>	606
	<i>Prospect Theory</i>	608
	<i>Framing</i>	610
	<i>Paradox of Choice</i>	610

<i>Multiple Steps in Reasoning</i>	611
<i>Evolution and Learning</i>	613
Application 17.2: <i>Cold Movie Openings</i>	614
<i>Self-Awareness</i>	615
Application 17.3: <i>Going for It on Fourth Down</i>	616
Application 17.4: <i>Let's Make a Deal</i>	617
Limited Willpower	618
<i>Hyperbolic Discounting</i>	618
<i>Numerical Example</i>	619
<i>Further Applications</i>	621
<i>Commitment Strategies</i>	621
Limited Self-Interest	623
<i>Altruism</i>	623
Application 17.5: "Put a Contract Out on Yourself"	624
<i>Fairness</i>	625
<i>Market versus Personal Dealings</i>	628
Application 17.6: <i>Late for Daycare Pickup</i>	629
Policy Implications	630
<i>Borrowing and Savings Decisions</i>	630
<i>Other Goods and Services</i>	631
<i>Market Solutions</i>	631
<i>"Nudging" the Market</i>	631
Summary	632
Review Questions	633
Problems	634
Glossary	637
Index	645



SOUTH-WESTERN
CENGAGE Learning™

NOT FOR SALE

Welcome to the eleventh edition of *Intermediate Microeconomics and Its Application*. This is the second edition of our co-authorship, and we hope that this edition will be even more enjoyable and easier to learn from than its predecessors. To those ends we have added a wide variety of new material to the text and streamlined the presentation of some of the basic theory. We have also added a number of student aids that we hope will enhance the ability to deal with the more analytical aspects of microeconomics. As always, however, the book retains its focus on providing a clear and concise treatment of intermediate microeconomics.

The principal addition to this edition in terms of content is an entirely new chapter on behavioral economics (Chapter 17). This is an area of microeconomics where research has been expanding greatly in recent years, and we believe it is important to give instructors the option to cover some of this fascinating material. In this chapter, we discuss cases in which traditional models of fully rational decision makers seem to be at odds with observed choice behavior (in the real world and laboratory experiments). We point out how the traditional models can be modified to handle these new considerations, building on what students should already know about microeconomics, stressing the linkages between this chapter and other parts of the text.

Many other chapters in this edition have been extensively rewritten. Some of the most important changes include:

- Combining the chapters on individual and market demand curves into a single, more compact chapter;
- Revising the basic chapter on behavior under uncertainty so that it is better coordinated with later material on game theory, asymmetric information, and behavioral economics;
- Merging what were previously two chapters on the competitive model and its applications into a single, unified treatment;
- Thoroughly revising the chapter on monopoly with the goal of stressing the connections between this chapter and the next one on imperfect competition; and
- Adding a variety of new material to the chapter on time in microeconomics.

Overall, we hope that these changes will increase the cohesiveness of the book by showing students the ways in which the many strands of microeconomics are interconnected.

We believe that the boxed applications in this book are a great scheme for getting students interested in economics. For this edition, we have updated all of our

PREFACE

favorite applications, dropped those that seem less compelling, and added about twenty-five new ones. We have tried to focus some of these new ones on issues that have arisen in the recent financial crisis. Some examples include:

- Stock Options and Accounting Fraud;
- Moral Hazard in the Financial Crisis;
- Household Financial Decisions; and
- Regulating the Scope of Banks.

Many other aspects of the crisis are mentioned in passing in the revised versions of our applications. The other new applications cover a broad range of topics including:

- The Energy Use Paradox;
- Choosing Standards for HD DVDs;
- Searching on the Internet;
- Costs of “Social Responsibility”;
- Pricing of Bagels and Catalogue Sales;
- Anti-Terrorism Strategy; and
- Fourth-Down Strategy in Football

We hope that the breadth of coverage of these applications will show students the wide array of topics to which economic analysis can be fruitfully applied.

For the eleventh edition, the two most significant additions to the many student aids in the book is the inclusion of **additional worked-out numerical examples**, and new **Policy Challenge discussions** at the ends of many of the Applications. We have included the worked-out examples to assist students in completing the numerical problems in the book (or those that might be assigned by instructors). Many of these examples conclude with a section we label “Keep in Mind,” where we offer some advice to students about how to avoid many of the most common pitfalls by students that we have encountered in our teaching. We have also improved the other student aids in the text by updating and refocusing many of the Micro-Quizzes, Review Questions, and Problems.

TO THE INSTRUCTOR

We have tried to organize this book in a way that most instructors will want to use it. We proceed in a very standard way through the topics of demand, supply, competitive equilibrium, and market structure before covering supplemental topics such as input markets, asymmetric information, or externalities. There are two important organizational decisions that instructors will need to make depending on their preferences. First is a decision about where to cover uncertainty and game theory. We have placed these topics near the front of the book (Chapters 4 and 5), right after the development of demand curves. The purpose of such an early placement is to provide students with some tools that they may find useful in subsequent chapters. But some users may find coverage of these topics so early in the course to be distracting and may therefore prefer to delay them until later. In any

case, they should be covered before the material on imperfect competition (Chapter 12) because that chapter makes extensive use of game theory concepts.

A second decision that must be made concerns our new chapter on behavioral economics (Chapter 17). We have placed this chapter at the end because it represents a departure from the paradigm used throughout the rest of the book. We realize that many instructors may not have the time or inclination to cover this additional topic. For those that do, one suggestion would be to cover it at the end of the term, providing students with an appreciation of the fact that economics is not cut-and-dried but is continually evolving as new ideas are proposed, tested, and refined. Another suggestion would be to sprinkle a few behavioral topics into the relevant places in the chapters on consumer choice, uncertainty, and game theory.

Previous users of this text will note that there are two places where two chapters have been merged into one. What were previously separate chapters on individual and market demand curves have now been combined into a single chapter on demand curves. We believe this is the more standard approach and will permit instructors to get to the “bottom line” (that is, market demand curves) more quickly. Second, we have merged what was previously a separate chapter on applications of the competitive model into the final portion of the chapter on perfect competition. This should allow the instructor to spend less time on these applications while, at the same time, allowing them to illustrate how the competitive model is the workhorse for most applied analysis.

Both of us have thoroughly enjoyed the correspondence we have had with users of our books over the years. If you have a chance, we hope you will let us know what you think of this edition and how it might be improved. Our goal is to provide a book that meshes well with each instructor’s specific style. The feedback that we have received has really helped us to develop this edition and we hope this process will continue.

TO THE STUDENT

We believe that the most important goal of any microeconomics course is to make this material interesting so that you will want to pursue economics further and begin to use its tools in your daily life. For this reason, we hope you will read most of our applications and think about how they might relate to you. But we also want you to realize that the study of economics is not all just interesting “stories.” There is a clear body of theory in microeconomics that has been developed over more than 200 years in an effort to understand the operations of markets. If you are to “think like an economist,” you will need to learn this theoretical core. We hope that the attractive format of this book together with its many learning aids will help you in that process. As always, we would be happy to hear from any student who would care to comment on our presentation. We believe this book has been improved immeasurably over the years by replying to students’ opinions and criticisms. We hope you will keep these coming. Words of praise would also be appreciated, of course.

SUPPLEMENTS TO THE TEXT

A wide and helpful array of supplements is available with this edition to both students and instructors.

- An Instructor's Manual with Test Bank, by Walter Nicholson and Christopher Snyder, contains summaries, lecture and discussion suggestions, a list of glossary terms, solutions to problems, a multiple-choice test bank, and suggested test problems. The Instructor's Manual with Test Bank is available on the text Web site at <http://www.cengage.com/economics/nicholson> to instructors only.
- Microsoft PowerPoint Slides, revised by Philip S. Heap, James Madison University, are available on the text Web site for use by instructors for enhancing their lectures.
- A Study Guide and Workbook, by Brett Katzman, Kennesaw College, includes learning objectives, fill-in summaries, multiple-choice questions, glossary questions, exercises involving quantitative problems, graphs, and answers to all questions and problems.
- The text Web site at <http://www.cengage.com/economics/nicholson> contains chapter Internet Exercises, online quizzes, instructor and student resources, economic applications, and more.
- Organized by pertinent economic categories and searchable by topic, these features are easy to integrate into the classroom. EconNews, EconDebate, and EconData all deepen your students' understanding of theoretical concepts with hands-on exploration and analysis through the latest economic news stories, policy debates, and data. These features are updated on a regular basis. The Economic Applications Web site is complementary to every new book buyer via an access card packaged with the books. Used book buyers can purchase access to the site at <http://econapps.swlearning.com>.

ACKNOWLEDGMENTS

Most of the ideas for this edition came from very productive meetings we had with Susan Smart and Mike Roche at Cengage Learning Publishing and from a series of reviews by Louis H. Amato, University of North Carolina at Charlotte; Gregory Besharov, Duke University; David M. Lang, California State University, Sacramento; Magnus Lofstrom, University of Texas, Dallas; Kathryn Nance, Fairfield University; Jeffrey O. Sundberg, Lake Forest College; Pete Tsournos, California State University, Chico; and Ben Young, University of Missouri, Kansas City. Overall, we learned quite a bit from this process and hope that we have been faithful to many of the helpful suggestions these people made.

Once again, it was the professional staff at Cengage Learning and its contractors that made this book happen. In addition to Susan Smart and Mike Roche, we owe a special thanks to Dawn Shaw, who guided the copyediting and production of the book. She proved especially adept at dealing with a variety of incompatibilities among the various electronic versions of the book, and we believe that will make life much easier for us in the long run. The Art Director for this edition was Michelle

Kunkler, who managed to devise ways to incorporate the many elements of the book into an attractive whole. We also thank our media editor, Deepak Kumar, and the marketing team—John Carey and Betty Jung—for their respective contributions.

We certainly owe a debt of gratitude to our families for suffering through another edition of our books. For Walter Nicholson, most of the cost has been borne by his wife of 42 years, Susan (who should know better by now). Fortunately, his ever expanding set of grandchildren has provided her with a well-deserved escape. The dedication of the book to them is intended both as gratitude to their being here and as a feeble attempt to get them to be interested in this ever-fascinating subject.

Christopher Snyder is grateful to his wife, Maura, for accommodating the long hours needed for this revision and for providing economic insights from her teaching of the material. He is grateful to his daughters, to whom he has dedicated this edition, for expediting the writing process by behaving themselves and for generally being a joy around the house. He also thanks his Dartmouth colleagues for helpful discussions and understanding. In particular, Jonathan Zinman provided extensive comments on the behavioral chapter.

Walter Nicholson
Amherst, Massachusetts
May 2009

Christopher Snyder
Hanover, New Hampshire
May 2009

SOUTH-WESTERN
CENGAGE Learning™



SOUTH-WESTERN
CENGAGE Learning™

NOT FOR SALE

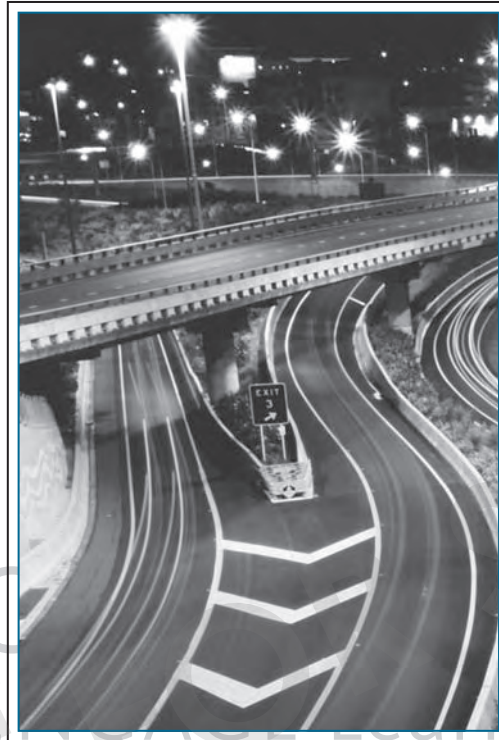

GAME THEORY

A central assumption in this text is that people make the best choices they can given their objectives. For example, in the theory of choice in Chapter 2, a consumer chooses the affordable bundle maximizing his or her utility. The setting was made fairly simple by considering a single consumer in isolation, justified by the assumption that consumers are price takers, small enough relative to the market that their actions do not measurably impact others.

Many situations are more complicated in that they involve strategic interaction. The best one person can do may often depend on what another does. How loud a student prefers to play his or her music may depend on how loud the student in the next dorm room plays his or hers.

The first student may prefer soft music unless louder music is needed to tune out the sound from next door. A gas station's profit-maximizing price may depend on what the competitor across the street charges. The station may wish to match or slightly undercut its competitor.

In this chapter, we will learn the tools economists use to deal with these strategic situations. The tools are quite general, applying to problems anywhere from the interaction between students in a dorm or players in a card game, all the way up to wars between countries. The tools are also particularly useful for analyzing the interaction among oligopoly firms, and we will draw on them extensively for this purpose later in the book.

BACKGROUND

Game theory was originally developed during the 1920s and grew rapidly during World War II in response to the need to develop formal ways of thinking about military strategy.¹ One branch of game theory, called cooperative game theory, assumes the group of players reaches an outcome that is best for the group as a whole, producing the largest “pie” to be shared among them; the theory focuses on rules for how the “pie” should be divided. We will focus mostly on the second branch, called noncooperative game theory, in which players are guided instead by self-interest. We focus on noncooperative game theory for several reasons. Self-interested behavior does not always lead to an outcome that is best for the players as a group (as we will see from the Prisoners’ Dilemma to follow), and such outcomes are interesting and practically relevant. Second, the assumption of self-interested behavior is the natural extension of our analysis of single-player decision problems in earlier chapters to a strategic setting. Third, one can analyze attempts to cooperate using noncooperative game theory. Perhaps most importantly, noncooperative game theory is more widely used by economists. Still, cooperative game theory has proved useful to model bargaining games and political processes.

BASIC CONCEPTS

Game theory models seek to portray complex strategic situations in a simplified setting. Like previous models in this book, a game theory model abstracts from many details to arrive at a mathematical representation of the essence of the situation. Any strategic situation can be modeled as game by specifying four basic elements: (1) players, (2) strategies, (3) payoffs, and (4) information.

Players

Each decision maker in a game is called a *player*. The players may be individuals (as in card games), firms (as in an oligopoly), or entire nations (as in military conflicts). The number of players varies from game to game, with two-player, three-player, or *n*-player games being possible. In this chapter, we primarily study two-player games since many of the important concepts can be illustrated in this simple setting. We usually denote these players by *A* and *B*.

Strategies

A player’s choice in a game is called a *strategy*. A strategy may simply be one of the set of possible actions available to the player, leading to the use of the terms *strategy* and *action* interchangeably in informal discourse. But a strategy can be more complicated than an action. A strategy can be a contingent plan of action based

¹Much of the pioneering work in game theory was done by the mathematician John von Neumann. The main reference is J. von Neumann and O. Morgenstern, *The Theory of Games and Economic Behavior* (Princeton, NJ: Princeton University Press, 1944).

on what another player does first (as will be important when we get to sequential games). A strategy can involve a random selection from several possible actions (as will be important when we get to mixed strategies). The actions underlying the strategies can range from the very simple (taking another card in blackjack) to the very complex (building an anti-missile defense system). Although some games offer the players a choice among many different actions, most of the important concepts in this chapter can be illustrated for situations in which each player has only two actions available. Even when the player has only two actions available, the set of strategies may be much larger once we allow for contingent plans or for probabilities of playing the actions.

Payoffs

The returns to the players at the conclusion of the game are called *payoffs*. Payoffs include the utilities players obtain from explicit monetary payments plus any implicit feelings they have about the outcome, such as whether they are embarrassed or gain self-esteem. It is sometimes convenient to ignore these complications and take payoffs simply to be the explicit monetary payments involved in the game. This is sometimes a reasonable assumption (for example, in the case of profit for a profit-maximizing firm), but it should be recognized as a simplification. Players seek to earn the highest payoffs possible.

Information

To complete the specification of a game, we need to specify what players know when they make their moves, called their *information*. We usually assume the structure of the game is common knowledge; each player knows not only the “rules of the game” but also that the other player knows, and so forth. Other aspects of information vary from game to game, depending on timing of moves and other issues. In simultaneous-move games, neither player knows the other’s action when moving. In sequential move games, the first mover does not know the second’s action but the second mover knows what the first did. In some games, called games of incomplete information, players may have an opportunity to learn things that others don’t know. In card games, for example, players see the cards in their own hand but not others’. This knowledge will influence play; players with stronger hands may tend to play more aggressively, for instance.²

The chapter will begin with simple information structures (simultaneous games), moving to more complicated ones (sequential games), leaving a full analysis of games of incomplete information until Chapter 16. A central lesson of game theory is that seemingly minor changes in players’ information may have a dramatic impact on the equilibrium of the game, so one needs to pay careful attention to specifying this element.

²We can still say that players share common knowledge about the “rules of the game” in that they all know the distribution of cards in the deck and the number that each will be dealt in a hand even though they have incomplete information about some aspects of the game, in this example the cards in others’ hands.

EQUILIBRIUM

Students who have taken a basic microeconomics course are familiar with the concept of market equilibrium, defined as the point where supply equals demand. (Market equilibrium is introduced in Chapter 1 and discussed further in Chapter 9.) Both suppliers and demanders are content with the market equilibrium: given the equilibrium price and quantity, no market participant has an incentive to change his or her behavior. The question arises whether there are similar concepts in game theory models. Are there strategic choices that, once made, provide no incentives for the players to alter their behavior given what others are doing?

The most widely used approach to defining equilibrium in games is named after John Nash for his development of the concept in the 1950s (see Application 5.1: A Beautiful Mind for a discussion of the movie that increased his fame). An integral part of this definition of equilibrium is the notion of a best response. Player A 's strategy a is a **best response** against player B 's strategy b if A cannot earn more from any other possible strategy given that B is playing b . A **Nash equilibrium** is a set of strategies, one for each player, that are mutual best responses. In a two-player game, a set of strategies (a^*, b^*) is a Nash equilibrium if a^* is player A 's best response against b^* and b^* is player B 's best response against a^* . A Nash equilibrium is stable in the sense that no player has an incentive to deviate unilaterally to some other strategy. Put another way, outcomes that are not Nash equilibria are unstable because at least one player can switch to a strategy that would increase his or her payoffs given what the other players are doing.

Nash equilibrium is so widely used by economists as an equilibrium definition because, in addition to selecting an outcome that is stable, a Nash equilibrium exists for all games. (As we will see, some games that at first appear not to have a Nash equilibrium will end up having one in mixed strategies.) The Nash equilibrium concept does have some problems. Some games have several Nash equilibria, some of which may be more plausible than others. In some applications, other equilibrium concepts may be more plausible than Nash equilibrium. The definition of Nash equilibrium leaves out the process by which players arrive at strategies they are prescribed to play. Economists have devoted a great deal of recent research to these issues, and the picture is far from settled. Still, Nash's concept provides an initial working definition of equilibrium that we can use to start our study of game theory.

ILLUSTRATING BASIC CONCEPTS

We can illustrate the basic components of a game and the concept of Nash equilibrium in perhaps the most famous of all noncooperative games, the Prisoners' Dilemma.

The Prisoners' Dilemma

First introduced by A. Tucker in the 1940s, its name stems from the following situation. Two suspects, A and B , are arrested for a crime. The district attorney has

Best response

A strategy that produces the highest payoff among all possible strategies for a player given what the other player is doing.

Nash equilibrium

A set of strategies, one for each player, that are each best responses against one another.

A Beautiful Mind

In 1994, John Nash won the Nobel Prize in economics for developing the equilibrium concept now known as Nash equilibrium. The publication of the best-selling biography *A Beautiful Mind* and the Oscar award-winning movie of the same title has made him world famous.¹

A Beautiful Blond

The movie dramatizes the development of Nash equilibrium in a single scene in which Nash is in a bar talking with his male classmates. They notice several women at the bar, one blond and the rest brunette, and it is posited that the blond is more desirable than the brunettes. Nash conceives of the situation as a game among the male classmates. If they all go for the blond, they will block each other and fail to get her, and indeed fail to get the brunettes because the brunettes will be annoyed at being second choice. He proposes that they all go for the brunettes. (The assumption is that there are enough brunettes that they do not have to compete for them, so the males will be successful in getting dates with them.) While they will not get the more desirable blond, each will at least end up with a date.

Confusion About Nash Equilibrium?

If it is thought that the Nash character was trying to solve for the Nash equilibrium of the game, he is guilty of making an elementary mistake! The outcome in which all male graduate students go for brunettes is not a Nash equilibrium. In a Nash equilibrium, no player can have a strictly profitable deviation given what the others are doing. But if all the other male graduate students went for brunettes, it would be strictly profitable for one of them to deviate and go for the blond because the deviator would have no competition for the blond, and she is assumed to provide a higher payoff. There are many Nash equilibria of this game, involving various subsets of males competing for the blond, but the outcome in which all males avoid the blond is not one of them.²

¹The book is S. Nasar, *A Beautiful Mind* (New York: Simon and Schuster, 1997) and the movie is *A Beautiful Mind* (Universal Pictures 2001).

²S. P. Anderson and M. Engers, "Participation Games: Market Entry, Coordination, and the Beautiful Blond," *Journal of Economic Behavior and Organization* (May 2007): 120–137.

Nash Versus the Invisible Hand

Some sense can be made of the scene if we view the Nash character's suggested outcome not as what he thought was the Nash equilibrium of the game but as a suggestion for how they might cooperate to move to a different outcome and increase their payoffs. One of the central lessons of game theory is that equilibrium does not necessarily lead to an outcome that is best for all. In this chapter, we study the Prisoners' Dilemma, in which the Nash equilibrium is for both players to Confess when they could both benefit if they could agree to be Silent. We also study the Battle of the Sexes, in which there is a Nash equilibrium where the players sometimes show up at different events, and this failure to coordinate ends up harming them both. The payoffs in the Beautiful Blond game can be specified in such a way that players do better if they all agree to ignore the blond than in the equilibrium in which all compete for the blond with some probability.³ Adam Smith's famous "invisible hand," which directs the economy toward an efficient outcome under perfect competition, does not necessarily operate when players interact strategically in a game. Game theory opens up the possibility of conflict, miscoordination, and waste, just as observed in the real world.

TO THINK ABOUT

1. How would you write down the game corresponding to the bar scene from *A Beautiful Mind*? What are the Nash equilibria of your game? Should the females be included as players in the setup along with the males?
2. One of Nash's classmates suggested that Nash was trying to convince the others to go after the brunettes so that Nash could have the blond for himself. Is this a Nash equilibrium? Are there others like it? How can one decide how a game will be played if there are multiple Nash equilibria?

³For example, the payoff to getting the blond can be set to 3, getting no date to 0, getting a brunette when no one else has gotten the blond to 2, and getting a brunette when someone else has gotten the blond to 1. Thus there is a loss due to envy if one gets the brunette when another has gotten the blond.

little evidence in the case and is anxious to extract a confession. She separates the suspects and privately tells each, “If you Confess and your partner doesn’t, I can promise you a reduced (one-year) sentence, and on the basis of your confession, your partner will get 10 years. If you both Confess, you will each get a three-year sentence.” Each suspect also knows that if neither of them confesses, the lack of evidence will cause them to be tried for a lesser crime for which they will receive two-year sentences.

The Game in Normal Form

The players in the game are the two suspects, *A* and *B*. (Though a third person, the district attorney, plays a role in the story, once she sets up the payoffs from confessing she does not make strategic decisions, so she does not need to be included in the game.) The players can choose one of two possible actions, Confess or Silent. The payoffs, as well as the players and actions, can be conveniently summarized, as shown in the matrix in Table 5.1. The representation of a game in a matrix like this is called the **normal form**. In the table, player *A*’s strategies, Confess or Silent, head the rows and *B*’s strategies head the columns. Payoffs corresponding to the various combinations of strategies are shown in the body of the table. Since more prison time causes disutility, the prison terms for various outcomes enter with negative signs. We will adopt the convention that the first payoff in each box corresponds to the row player (player *A*) and the second corresponds to the column player (player *B*). To make this convention even clearer, we will make player *A*’s strategies and payoffs a different color than *B*’s. For an example of how to read the table, if *A* Confesses and *B* is Silent, *A* earns -1 (for one year of prison) and *B* earns -10 (for 10 years of prison). The fact that the district attorney approaches each separately indicates that the game is simultaneous: a player cannot observe the other’s action before choosing his or her own action.

Normal form

Representation of a game using a payoff matrix.

Extensive form

Representation of a game as a tree.

TABLE 5.1

Prisoners’ Dilemma in Normal Form

		<i>B</i>	
		Confess	Silent
<i>A</i>	Confess	$-3, -3$	$-1, -10$
	Silent	$-10, -1$	$-2, -2$

The Game in Extensive Form

The Prisoners’ Dilemma game can also be represented as a game tree as in Figure 5.1, called the **extensive form**. Action proceeds from top to bottom. Each dark circle is a decision point for the player indicated there. The first move belongs to *A*, who can choose to Confess or be Silent. The next move belongs to *B*, who can also choose to Confess or be Silent. Payoffs are given at the bottom of the tree.

To reflect the fact that the Prisoners’ Dilemma is a simultaneous game, we would like the two players’ moves to appear in the same level in the tree, but the structure of a tree prevents us from doing that. To avoid this problem, we can arbitrarily choose one player (here *A*) to be at the top of the tree as the first mover and the other to be lower as the second mover, but then we draw an oval around *B*’s decision points to reflect the fact that *B* does not observe which

FIGURE 5.1

Prisoners' Dilemma in Extensive Form

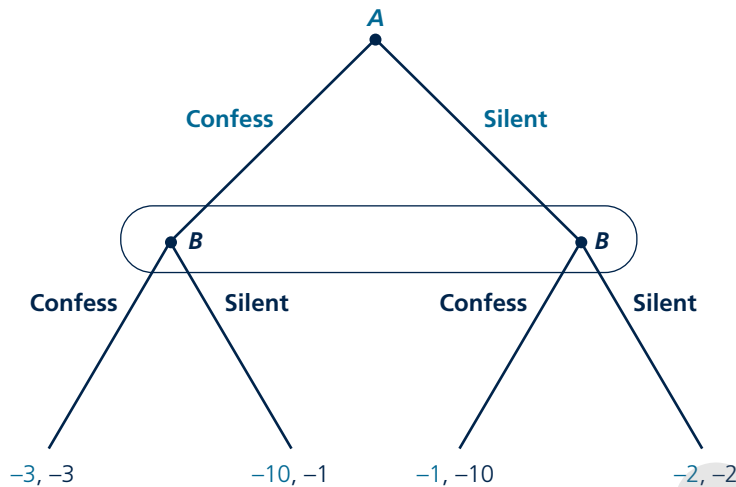

A chooses to Confess or be Silent, and B makes a similar choice. The oval surrounding B's decision points indicates that B cannot observe A's choice when B moves, since the game is simultaneous. Payoffs are listed at the bottom.

action A has chosen and so does not observe which decision point has been reached when he or she makes his or her decision.

The choice to put A above B in the extensive form was arbitrary: we would have obtained the same representation if we put B above A and then had drawn an oval around A's decision points. As we will see when we discuss sequential games, having an order to the moves only matters if the second mover can observe the first mover's action. It usually is easier to use the extensive form to analyze sequential games and the normal form to analyze simultaneous games. Therefore, we will return to the normal-form representation of the Prisoners' Dilemma to solve for its Nash equilibrium.

Solving for the Nash Equilibrium

Return to the normal form of the Prisoners' Dilemma in Table 5.1. Consider each box in turn to see if any of the corresponding pairs of strategies constitute a Nash equilibrium. First consider the lower right box, corresponding to both players choosing Silent. There is reason to think this is the equilibrium of the game since the sum of the payoffs, -4 , is greater than the sum of the payoffs in any of the other three outcomes (since all sums are negative, by "the greatest sum" we mean the one closest to 0). However, both playing Silent is in fact not a Nash equilibrium. To be a Nash equilibrium, both players' strategies must be best responses to each other. But given that B plays Silent, A can increase his or her payoff from -2 to -1 by deviating from Silent to Confess. Therefore, Silent is not A's best response to B's

KEEP in MIND**Specify Equilibrium Strategies**

The temptation is to say that the Nash equilibrium is $(-3, -3)$. This is not technically correct. Recall that the definition of Nash equilibrium involves a set of strategies, so it is proper to refer to the Nash equilibrium in the Prisoners' Dilemma as "both players choose Confess." True, each outcome corresponds to unique payoffs in this game, so there is little confusion in referring to an equilibrium by the associated payoffs rather than strategies. However, we will come across games later in the chapter in which different outcomes have the same payoffs, so referring to equilibria by payoffs leads to ambiguity.

playing Silent. (It is also true that B 's playing Silent is not a best response to A 's playing Silent, although demonstrating that at least one of the two players was not playing his or her best response was enough to rule out an outcome as being a Nash equilibrium.) Next consider the top right box, where A plays Confess and B plays Silent. This is not a Nash equilibrium either. Given that A plays Confess, B can increase his or her payoff from -10 in the proposed equilibrium to -3 by deviating from Silent to Confess. Similarly, the bottom left box, in which A plays Silent and B plays Confess, can be shown not to be a Nash equilibrium since A is not playing a best response.

The remaining upper left box corresponds to both playing Confess. This is a Nash equilibrium. Given B plays Confess, A 's best response is Confess since this leads A to earn -3 rather than -10 . By the

same logic, Confess is B 's best response to A 's playing Confess.

Rather than going through each outcome one by one, there is a shortcut to finding the Nash equilibrium directly by underlining payoffs corresponding to best responses. This method is useful in games having only two actions having small payoff matrices but becomes extremely useful when the number of actions increases and the payoff matrix grows. The method is outlined in Table 5.2. The first step is to compute A 's best response to B 's playing Confess. A compares his or her payoff in the first column from playing Confess, -3 , to playing Silent, -10 . The payoff -3 is higher than -10 , so Confess is A 's best response, and we underline -3 . In step 2, we underline -1 , corresponding to A 's best response, Confess, to B 's playing Silent. In step 3, we underline -3 , corresponding to B 's best response to A 's playing Confess. In step 4, we underline -1 , corresponding to B 's best response to A 's playing Silent.

For an outcome to be a Nash equilibrium, both players must be playing a best response to each other. Therefore, both payoffs in the box must be underlined. As seen in step 5, the only box in which both payoffs are underlined is the upper left, with both players choosing Confess. In the other boxes, either one or no payoffs are underlined, meaning that one or both of the players are not playing a best response in these boxes, so they cannot be Nash equilibria.

Dominant Strategies

Referring to step 5 in Table 5.2, not only is Confess a best response to the other players' equilibrium strategy (all that is required for Nash equilibrium), Confess is a best response to all strategies the other player might choose, called a **dominant strategy**. When a player has a dominant strategy in a game, there is good reason to predict that this is how the player will play the game. The player does not need to make a strategic calculation, imagining what the other might do in equilibrium. The player has one strategy that is best, regardless of what the other does. In most

Dominant strategy

Best response to all of the other player's strategies.

TABLE 5.2

Finding the Nash Equilibrium of the Prisoners' Dilemma Using the Underlining Method

Step 1: Underline payoff for A's best response to B's playing Confess.

		B	
		Confess	Silent
A	Confess	<u>-3</u> , -3	-1, -10
	Silent	-10, -1	-2, -2

Step 2: Underline payoff for A's best response to B's playing Silent.

		B	
		Confess	Silent
A	Confess	<u>-3</u> , -3	-1, <u>-10</u>
	Silent	-10, -1	-2, <u>-2</u>

Step 3: Underline payoff for B's best response to A's playing Confess.

		B	
		Confess	Silent
A	Confess	-3, <u>-3</u>	-1, <u>-10</u>
	Silent	-10, -1	-2, -2

Step 4: Underline payoff for B's best response to A's playing Silent.

		B	
		Confess	Silent
A	Confess	<u>-3</u> , <u>-3</u>	-1, -10
	Silent	-10, <u>-1</u>	-2, <u>-2</u>

Step 5: Nash equilibrium in box with both payoffs underlined.

		B	
		Confess	Silent
A	Confess	<u>-3</u> , <u>-3</u>	-1, -10
	Silent	-10, <u>-1</u>	-2, -2

games, players do not have dominant strategies, so dominant strategies would not be a generally useful equilibrium definition (while Nash equilibrium is, since it exists for all games).

The Dilemma The game is called the Prisoners' "Dilemma" because there is a better outcome for both players than the equilibrium. If both were Silent, they would each only get two years rather than three. But both being Silent is not stable; each would prefer to deviate to Confess. If the suspects could sign binding contracts, they would sign a contract that would have them both choose Silent. But such contracts would be difficult to write because the district attorney approaches each suspect privately, so they cannot communicate; and even if they could sign a contract, no court would enforce it.

Situations resembling the Prisoners' Dilemma arise in many real world settings. The best outcome for students working on a group project together might be for all to work hard and earn a high grade on the project, but the individual incentive to shirk, each relying on the efforts of others, may prevent them from attaining such an outcome. A cartel agreement among dairy farmers to restrict output would lead to higher prices and profits if it could be sustained, but may be unstable because it may be too tempting for an individual farmer to try to sell more milk at the high price. We will study the stability of business cartels more formally in Chapter 12.

Mixed Strategies

To analyze some games, we need to allow for more complicated strategies than simply choosing a single action with certainty, called a **pure strategy**. We will next consider **mixed strategies**, which have the player randomly select one of several possible actions. Mixed strategies are illustrated in another classic game, Matching Pennies.

Pure strategy

A single action played with certainty.

Mixed strategy

Randomly selecting from several possible actions.

TABLE 5.3

Matching Pennies Game
in Normal Form

		B	
		Heads	Tails
A	Heads	1, -1	-1, 1
	Tails	-1, 1	1, -1

Matching Pennies

Matching Pennies is based on a children's game in which two players, *A* and *B*, each secretly choose whether to leave a penny with its head or tail facing up. The players then reveal their choices simultaneously. *A* wins *B*'s penny if the coins match (both Heads or both Tails), and *B* wins *A*'s penny if they do not. The normal form for the game is given in Table 5.3 and the extensive form in Figure 5.2. The game has the special property that the two players' payoffs in each box add to zero, called a zero-sum game. The reader can check that the Prisoner's Dilemma is not a zero-sum game because the sum of players' payoffs varies across the different boxes.

To solve for the Nash equilibrium, we will use the method of underlining payoffs for best responses introduced previously for the Prisoners' Dilemma. Table 5.4

FIGURE 5.2

Matching Pennies Game in Extensive Form

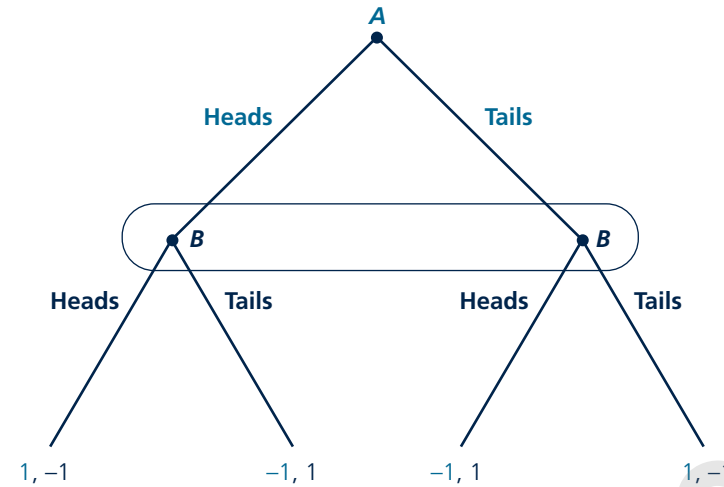

presents the results from this method. *A* always prefers to play the same action as *B*. *B* prefers to play a different action from *A*. There is no box with both payoffs underlined, so we have not managed to find a Nash equilibrium. It is tempting to say that no Nash equilibrium exists for this game. But this contradicts our earlier claim that all games have Nash equilibria. The contradiction can be resolved by noting that Matching Pennies does have a Nash equilibrium, not in pure strategies, as would be found by our underlining method, but in mixed strategies.

Solving for a Mixed-Strategy Nash Equilibrium

Rather than choosing Heads or Tails, suppose players secretly flip the penny and play whatever side turns up. The result of this strategy is a random choice of Heads with probability $\frac{1}{2}$ and Tails with probability $\frac{1}{2}$. This set of strategies, with both playing Heads or Tails with equal chance, is the mixed-strategy Nash equilibrium of the game. To verify this, we need to show that both players' strategies are best responses to each other.

In the proposed equilibrium, all four outcomes corresponding to the four boxes in the normal form in Table 5.3 are equally likely to occur, each occurring with probability $\frac{1}{4}$. Using the formula for expected payoffs from the

TABLE 5.4

Solving for Pure-Strategy Nash Equilibrium in Matching Pennies Game

		B	
		Heads	Tails
A	Heads	<u>1</u> , -1	-1, <u>1</u>
	Tails	-1, <u>1</u>	<u>1</u> , -1

previous chapter, A 's expected payoff equals the probability-weighted sum of the payoffs in each outcome:

$$(\frac{1}{4})(1) + (\frac{1}{4})(-1) + (\frac{1}{4})(-1) + (\frac{1}{4})(1) = 0.$$

Similarly, B 's expected payoff is also 0. The mixed strategies in the proposed equilibrium are best responses to each other if neither player can deviate to a strategy that produces a strictly higher payoff than 0. But there is no such profitable deviation. Given that B plays Heads and Tails with equal probabilities, the players' coins will match exactly half the time, whether A chooses Heads or Tails (or indeed even some random combination of the two actions); so A 's payoff is 0 no matter what strategy it chooses. A cannot earn more than the 0 it earns in equilibrium. Similarly, given A is playing Heads and Tails with equal probabilities, B 's expected

payoff is 0 no matter what strategy it uses. So neither player has a strictly profitable deviation. (It should be emphasized here that if a deviation produces a tie with the player's equilibrium payoff, this is not sufficient to rule out the equilibrium; to rule out an equilibrium, one must demonstrate a deviation produces a strictly higher payoff.)

Both players playing Heads and Tails with equal probabilities is the only mixed-strategy Nash equilibrium in this game. No other probabilities would work. For example, suppose B were to play Heads with probability $\frac{1}{3}$ and Tails with probability $\frac{2}{3}$. Then A would earn an expected payoff of $(\frac{1}{3})(1) + (\frac{2}{3})(-1) = -\frac{1}{3}$ from playing Heads and $(\frac{1}{3})(-1) + (\frac{2}{3})(1) = \frac{1}{3}$ from playing Tails. Therefore, A would strictly prefer to play Tails as a pure strategy rather than playing a mixed strategy involving both Heads and Tails, and so B 's playing Heads with probability $\frac{1}{3}$ and Tails with probability $\frac{2}{3}$ cannot be a mixed-strategy Nash equilibrium.

Micro Quiz 5.1

In Matching Pennies, suppose B plays the equilibrium mixed strategy of Heads with probability $\frac{1}{2}$ and Tails with probability $\frac{1}{2}$. Use the formula for expected values to verify that A 's expected payoff equals 0 from using any of the following strategies.

1. The pure strategy of Heads.
2. The pure strategy of Tails.
3. The mixed strategy of Heads with probability $\frac{1}{2}$ and Tails with probability $\frac{1}{2}$.
4. The mixed strategy of Heads with probability $\frac{1}{3}$ and Tails with probability $\frac{2}{3}$.

KEEP *in* MIND

Indifferent Among Random Actions

In any mixed-strategy equilibrium, players must be indifferent between the actions that are played with positive probability. If a player strictly preferred one action over another, the player would want to put all of the probability on the preferred action and none on the other action.

Interpretation of Random Strategies

Although at first glance it may seem bizarre to have players flipping coins or rolling dice in secret to determine their strategies, it may not be so unnatural in children's games such as Matching Pennies. Mixed strategies are also natural and common in sports, as discussed in Application 5.2: Mixed Strategies in Sports. Perhaps most familiar to students is the role of mixed strategies in class exams. Class

time is usually too limited for the professor to examine students on every topic taught in class. But it may be sufficient to test students on a subset of topics to get them to study all of the material. If students knew which topics are on the test, they

Mixed Strategies in Sports

Sports provide a setting in which mixed strategies arise quite naturally, and in a simple enough setting that we can see game theory in operation.

Soccer Penalty Kicks

In soccer, if a team commits certain offenses near its own goal, the other team is awarded a penalty kick, effectively setting up a game between the kicker and the goalie. Table 1 is based on a study of penalty kicks in elite European soccer leagues.¹ The first entry in each box is the frequency the penalty kick scores (taken to be the kicker's payoff), and the second entry is the frequency it does not score (taken to be the goalie's payoff). Kickers are assumed to have two actions: aim toward the "natural" side of the goal (left for right-footed kickers and right for left-footed players) or aim toward the other side. Kickers can typically kick harder and more accurately to their natural side. Goalies can try to jump one way or the other to try to block the kick. The ball travels too fast for the goalie to react to its direction, so the game is effectively simultaneous. Goalies know from scouting reports what side is natural for each kicker, so they can condition their actions on this information.

Do Mixed Strategies Predict Actual Outcomes?

Using the method of underlining payoffs corresponding to best responses, as shown in Table 1, we see that no box has both payoffs underlined, so there is no pure-strategy Nash equilibrium.

Following the same steps used to compute the mixed-strategy Nash equilibrium in the Battle of the Sexes, one can show that the kicker kicks to his natural side $\frac{3}{5}$ of the time and $\frac{2}{5}$ of the time to his other side; the goalie jumps to the side that is natural for the kicker $\frac{2}{3}$ of the time and the other side $\frac{1}{3}$ of the time.

This calculation generates several testable implications. First, both actions have at least some chance of being played. This is borne out in the Chiappori et al. data: almost all of the kickers and goalies who are involved in three or more penalty kicks in the data choose each action at least once. Second, players

¹P. -A. Chiappori, S. Levitt, and T. Groseclose, "Testing Mixed-Strategy Equilibria When Players Are Heterogeneous: The Case of Penalty Kicks in Soccer," *American Economic Review* (September 2002): 1138–1151.

TABLE 1

Soccer Penalty Kick Game

		Goalie	
		Natural side for kicker	Other side
Kicker	Natural side for kicker	.64, <u>.36</u>	<u>.94</u> , .06
	Other side	<u>.89</u> , .11	.44, <u>.56</u>

obtain the same expected payoff in equilibrium regardless of the action taken. This is again borne out in the data, with kickers scoring about 75 percent of the time, whether they kick to their natural side or the opposite, and goalies being scored on about 75 percent of the time, whether they jump to the kicker's natural side or the opposite. Third, the goalie should jump to the side that is natural for the kicker more often. Otherwise, the higher speed and accuracy going to his natural side would lead the kicker to play the pure strategy of always kicking that way. Again, this conclusion is borne out in the data, with the goalie jumping to the kicker's natural side 60 percent of the time (note how close this is to the prediction of $\frac{2}{3}$ we made above).

TO THINK ABOUT

1. Verify the mixed-strategy Nash equilibrium computed above for the penalty-kick game following the methods used for the Battle of the Sexes.
2. Economists have studied mixed strategies in other sports, for example whether a tennis serve is aimed to the returner's backhand or forehand.² Can you think of other sports settings involving mixed strategies? Can you think of settings outside of sports and games and besides the ones noted in the text?

²M. Walker and J. Wooders, "Minimax Play at Wimbledon," *American Economic Review* (December 2001), 1521–1538.

TABLE 5.5

Battle of the Sexes in Normal Form

		B (Husband)	
		Ballet	Boxing
A (Wife)	Ballet	2, 1	0, 0
	Boxing	0, 0	1, 2

may be inclined to study only those and not the others, so the professor must choose which topics to include at random to get the students to study everything.

MULTIPLE EQUILIBRIA

Nash equilibrium is a useful solution concept because it exists for all games. A drawback is that some games have several or even many Nash equilibria. The possibility of multiple equilibria causes a problem for economists who would like to use game theory to make predictions, since it is unclear which of the Nash equilibria one should predict will happen. The possibility of multiple equilibria is illustrated in yet another classic game, the Battle of the Sexes.

Battle of the Sexes

The game involves two players, a wife (*A*) and a husband (*B*) who are planning an evening out. Both prefer to be together rather than apart. Conditional on being together, the wife would prefer to go to a Ballet performance and the husband to a Boxing match. The normal form for the game is given in Table 5.5 and the extensive form in Figure 5.3.

To solve for the Nash equilibria, we will use the method of underlining payoffs for best responses introduced previously. Table 5.6 presents the results from this method. A player's best response is to play the same action as the other. Both payoffs are underlined in two boxes: the box in which both play Ballet and also in the box in

FIGURE 5.3

Battle of the Sexes in Extensive Form

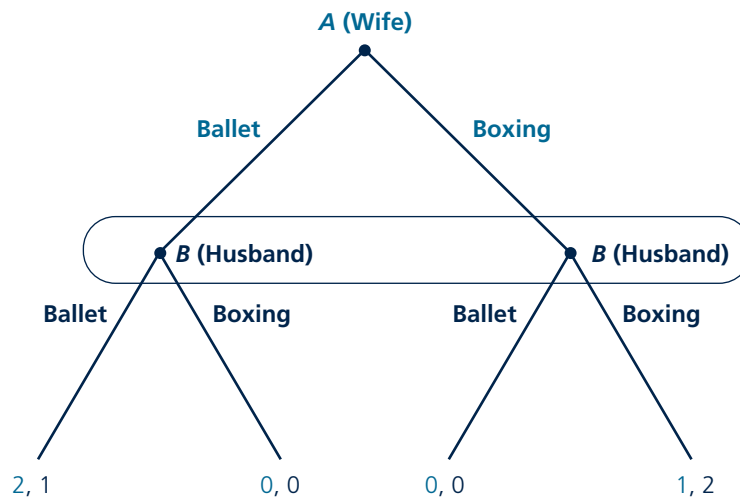

which both play Boxing. Therefore, there are two pure-strategy Nash equilibria: (1) both play Ballet and (2) both play Boxing.

The problem of multiple equilibria is even worse than at first appears. Besides the two pure-strategy Nash equilibria, there is a mixed-strategy one. How does one know this? One could find out for sure by performing all of the calculations necessary to find a mixed-strategy Nash equilibrium. Even without doing any calculations, one could guess that there would be a mixed-strategy Nash equilibrium based on a famous but peculiar result that Nash equilibria tend to come in odd numbers. Therefore, finding an even number of pure-strategy Nash equilibria (two in this game, zero in Matching Pennies) should lead one to suspect that the game also has another Nash equilibrium, in mixed strategies.

TABLE 5.6

Solving for Pure-Strategy Nash Equilibria in the Battle of the Sexes

		B (Husband)	
		Ballet	Boxing
A (Wife)	Ballet	<u>2, 1</u>	0, 0
	Boxing	0, 0	<u>1, 2</u>

Computing Mixed Strategies in the Battle of the Sexes

It is instructive to go through the calculation of the mixed-strategy Nash equilibrium in the Battle of the Sexes since, unlike in Matching Pennies, the equilibrium probabilities do not end up being equal ($1/2$) for each action. Let w be the probability the wife plays Ballet and h the probability the husband plays Ballet. Because probabilities of exclusive and exhaustive events must add to one, the probability of playing Boxing is $1 - w$ for the wife and $1 - h$ for the husband; so once we know the probability each plays Ballet, we automatically know the probability each plays Boxing. Our task then is to compute the equilibrium values of w and h . The difficulty now is that w and h may potentially be any one of a continuum of values between 0 and 1, so we cannot set up a payoff matrix and use our underlining method to find best responses. Instead, we will graph players' **best-response functions**.

Let us start by computing the wife's best-response function. The wife's best-response function gives the w that maximizes her payoff for each of the husband's possible strategies, h . For a given h , there are three possibilities: she may strictly prefer to play Ballet; she may strictly prefer to play Boxing; or she may be indifferent between Ballet and Boxing. In terms of w , if she strictly prefers to play Ballet, her best response is $w = 1$. If she strictly prefers to play Boxing, her best response is $w = 0$. If she is indifferent about Ballet and Boxing, her best response is a tie between $w = 1$ and $w = 0$; in fact, it is a tie among $w = 0$, $w = 1$, and all values of w between 0 and 1!

To see this last point, suppose her expected payoff from playing both Ballet and Boxing is, say, $2/3$, and suppose she randomly plays Ballet and Boxing with probabilities w and $1 - w$. Her expected payoff (this should be reviewed, if necessary, from Chapter 5) would equal the probability she plays Ballet times her expected payoff if she plays Ballet plus the probability she plays Boxing times her expected payoff if she plays Boxing:

$$(w)(2/3) + (1 - w)(2/3) = 2/3.$$

Best-response function
Function giving the payoff-maximizing choice for one player for each of a continuum of strategies of the other player.

This shows that she gets the same payoff, $\frac{2}{3}$, whether she plays Ballet for sure, Boxing for sure, or a mixed strategy involving any probabilities w , $1 - w$ of playing Ballet and Boxing. So her best response would be a tie among $w = 0$, $w = 1$, and all values in between.

Returning to the computation of the wife's best-response function, suppose the husband plays a mixed strategy of Ballet probability h and Boxing with probability $1 - h$. Referring to Table 5.7, her expected payoff from playing Ballet equals h (the probability the husband plays Ballet, and so they end up in Box 1) times 2 (her payoff in Box 1) plus $1 - h$ (the probability he plays Boxing, and so they end up in Box 2) times 0 (her payoff in Box 2), for a total expected payoff, after simplifying, of $2h$. Her expected payoff from playing Boxing equals h (the probability the husband plays Ballet, and so they end up in Box 3) times 0 (her payoff in Box 3) plus $1 - h$ (the probability he plays Boxing, and so they end up in Box 4) times 1 (her payoff in Box 4) for a total expected payoff, after simplifying, of $1 - h$.

Comparing these two expected payoffs, we can see that she prefers Boxing if $2h < 1 - h$ or, rearranging, $h < \frac{1}{3}$. She prefers Ballet if $> \frac{1}{3}$. She is indifferent between Ballet and Boxing if $h = \frac{1}{3}$. Therefore, her best response to $h < \frac{1}{3}$ is $w = 0$, to $h > \frac{1}{3}$ is $w = 1$, and to $h = \frac{1}{3}$ includes $w = 0$, $w = 1$, and all values in between.

Figure 5.4 graphs her best-response function as the light-colored curve. Similar calculations can be used to derive the husband's best-response function, the dark-colored curve. The best-response functions intersect in three places. These intersections are mutual best responses and hence Nash equilibria. The figure allows us to recover the two pure-strategy Nash equilibria found before: the one in which $w = h = 1$ (that is, both play Ballet for sure) and the one in which $w = h = 0$ (that is, both play Boxing for sure). We also obtain the mixed-strategy Nash equilibrium $w = \frac{2}{3}$ and $h = \frac{1}{3}$. In words, the mixed-strategy Nash equilibrium involves the wife's playing Ballet with probability $\frac{2}{3}$ and Boxing with probability $\frac{1}{3}$ and the husband's playing Ballet with probability $\frac{1}{3}$ and Boxing with probability $\frac{2}{3}$.

At first glance, it seems that the wife puts more probability on Ballet because she prefers Ballet conditional on coordinating and the husband puts more probability on Boxing because he prefers Boxing conditional on coordinating. This intuition is

TABLE 5.7

Computing the Wife's Best Response to the Husband's Mixed Strategy

		B (Husband)		
		Ballet h	Boxing $1 - h$	
A (Wife)	Ballet	Box 1 (2, 1)	Box 2 (0, 0)	$(h)(2) + (1 - h)(0)$ $= 2h$
	Boxing	Box 3 (0, 0)	Box 4 (1, 2)	$(h)(0) + (1 - h)(1)$ $= 1 - h$

FIGURE 5.4

Best-Response Functions Allowing for Mixed Strategies in the Battle of the Sexes

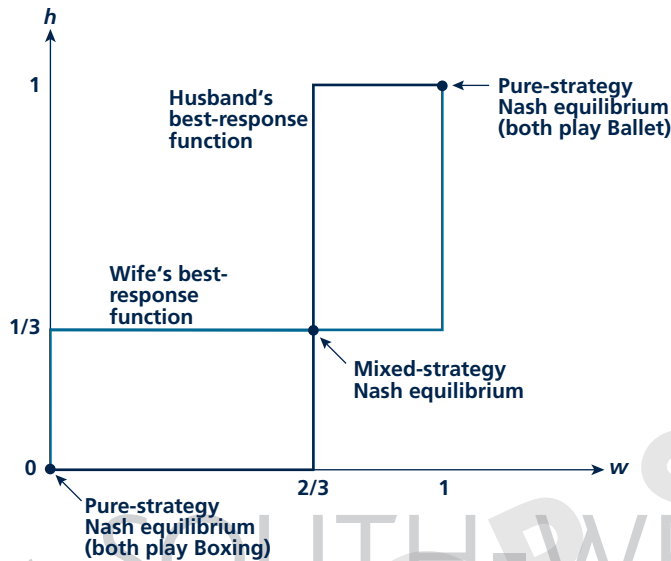

misleading. The wife, for example, is indifferent between Ballet and Boxing in the mixed-strategy Nash equilibrium given her husband's strategy. She does not care what probabilities she plays Ballet and Boxing. What pins down her equilibrium probabilities is not her payoffs but her husband's. She has to put less probability on the action he prefers conditional on coordinating (Boxing) than on the other action (Ballet) or else he would not be indifferent between Ballet and Boxing and the probabilities would not form a Nash equilibrium.

The Problem of Multiple Equilibria

Given that there are multiple equilibria, it is difficult to make a unique prediction about the outcome of the game. To solve this problem, game theorists have devoted a considerable amount of research to refining the Nash equilibrium concept, that is, coming up with good reasons for picking out one Nash equilibrium as being more "reasonable" than others. One suggestion would be to select the outcome with the highest total payoffs for the two players. This rule would eliminate the mixed-strategy Nash equilibrium in favor of one of the two pure-strategy equilibria. In the mixed-strategy equilibrium, we showed that each player's expected payoff is $\frac{2}{3}$ no matter which action is chosen, implying that the total expected payoff for the two

Micro Quiz 5.2

1. In the Battle of the Sexes, does either player have a dominant strategy?
2. In general, can a game have a mixed-strategy Nash equilibrium if a player has a dominant strategy? Why or why not?

players is $\frac{2}{3} + \frac{2}{3} = \frac{4}{3}$. In the two pure-strategy equilibria, total payoffs, equal to 3, exceed the total expected payoff in the mixed-strategy equilibrium.

Focal point

Logical outcome on which to coordinate, based on information outside of the game.

A rule that selects the highest total payoff would not distinguish between the two pure-strategy equilibria. To select between these, one might follow T. Schelling's suggestion and look for a **focal point**.³ For example, the equilibrium in which both play Ballet might be a logical focal point if the couple had a history of deferring to the wife's wishes on previous occasions. Without access to this external information on previous interactions, it would be difficult for a game theorist to make predictions about focal points, however.

Another suggestion would be, absent a reason to favor one player over another, to select the symmetric equilibrium. This rule would pick out the mixed-strategy Nash equilibrium because it is the only one that has equal payoffs (both players' expected payoffs are $\frac{2}{3}$).

Unfortunately, none of these selection rules seems particularly compelling. The Battle of the Sexes is one of those games for which there is simply no good way to solve the problem of multiple equilibria. Application 5.3: High-definition Standards War provides a real-world example with multiple equilibria. The difficulty in using game theory to determine the outcome in this market mirrors the difficulty in predicting which standard would end up dominating the market.

SEQUENTIAL GAMES

In some games, the order of moves matters. For example, in a bicycle race with a staggered start, the last racer has the advantage of knowing the time to beat. With new consumer technologies, for example, high-definition video disks, it may help to wait to buy until a critical mass of others have and so there are a sufficiently large number of program channels available.

Sequential games differ from the simultaneous games we have considered so far in that a player that moves after another can learn information about the play of the game up to that point, including what actions other players have chosen. The player can use this information to form more sophisticated strategies than simply choosing an action; the player's strategy can be a contingent plan, with the action played depending on what the other players do.

To illustrate the new concepts raised by sequential games, and in particular to make a stark contrast between sequential and simultaneous games, we will take a simultaneous game we have discussed already, the Battle of the Sexes, and turn it into a sequential game.

The Sequential Battle of the Sexes

Consider the Battle of the Sexes game analyzed previously with all the same actions and payoffs, but change the order of moves. Rather than the wife and husband making a simultaneous choice, the wife moves first, choosing Ballet or Boxing, the husband observes this choice (say the wife calls him from her chosen

³T. Schelling, *The Strategy of Conflict* (Cambridge, MA: Harvard University Press, 1960).

location), and then the husband makes his choice. The wife's possible strategies have not changed: she can choose the simple actions Ballet or Boxing (or perhaps a mixed strategy involving both actions, although this will not be a relevant consideration in the sequential game). The husband's set of possible strategies has expanded. For each of the wife's two actions, he can choose one of two actions, so he has four possible strategies, which are listed in Table 5.8. The vertical bar in the second equivalent way of writing the strategies means "conditional on," so, for example, "Boxing | Ballet" should be read "the husband goes to Boxing conditional on the wife's going to Ballet." The husband still can choose a simple action, with "Ballet" now interpreted as "always go to Ballet" and "Boxing" as "always go to Boxing," but he can also follow her or do the opposite.

Given that the husband has four pure strategies rather than just two, the normal form, given in Table 5.9, must now be expanded to have eight boxes. Roughly speaking, the normal form is twice as complicated as that for the simultaneous version of the game in Table 5.5. By contrast, the extensive form, given in Figure 5.5, is no more complicated than the extensive form for the simultaneous version of the game in Figure 5.3. The only difference between the extensive forms is that the oval around the husband's decision points has been removed. In the sequential version of the game, the husband's decision points are not gathered together in a dotted oval because the husband observes his wife's action and so knows which one he is on before moving. We can begin to see why the extensive form becomes more useful than the normal form for sequential games, especially in games with many rounds of moves.

To solve for the Nash equilibria, we will return to the normal form and use the method of underlining payoffs for best responses introduced previously. Table 5.10 presents the results from this method. One complication that arises in the method of underlining payoffs is that there are ties for best responses in this game. For example, if the husband plays the strategy "Boxing | Ballet, Ballet | Boxing," that is, if he does the opposite of his wife, then she earns zero no matter what action she chooses. To apply the underlining method properly, we need to underline both zeroes in the third column. There are also ties between the husband's best responses to his wife's playing Ballet (his payoff is 1 if he plays either "Ballet | Ballet, Ballet | Boxing" or "Ballet | Ballet, Boxing | Boxing") and to his wife's playing Boxing (his payoff is 2 if he plays either "Ballet | Ballet, Boxing | Boxing" or "Boxing | Ballet, Boxing | Boxing"). Again, as shown in the table, we need to underline the payoffs for all the strategies that tie for the best response. There are three pure-strategy Nash equilibria:

1. Wife plays Ballet, husband plays "Ballet | Ballet, Ballet | Boxing."
2. Wife plays Ballet, husband plays "Ballet | Ballet, Boxing | Boxing."
3. Wife plays Boxing, husband plays "Boxing | Ballet, Boxing | Boxing."

As with the simultaneous version of the Battle of the Sexes, with the sequential version we again have multiple equilibria. Here, however, game theory offers a good way to select among the equilibria. Consider the third Nash equilibrium. The husband's strategy, "Boxing | Ballet, Boxing | Boxing," involves an implicit threat

A P P L I C A T I O N 5.3

High-Definition Standards War

The discussion so far has made a strong case that players in games like Matching Pennies and sports like soccer behave strategically. Microeconomics courses typically do not concentrate on sports and games, however, but on consumer and firm behavior. Are there applications in these areas in which it is obvious that participants behave strategically?

Participants in the Standards War

We will spend most of Chapter 12 applying game theory to firms' pricing and output decisions. But perhaps an even starker example of strategic behavior by firms and consumers is the "war" over the new standard for high-definition video disks.¹ Two groups undertook independent research on incompatible technologies for the storage of high-resolution movies on optical disks: one led by Sony with its Blu-Ray format, the other by Toshiba with HD-DVD. Each format had some minor advantages (one offering more storage for supplementary material, the other better copy protection), but both provided similar picture quality with a six-times finer resolution than the existing DVD standard. After spending billions in research, development, and plant construction, Sony and Toshiba marketed their first players within months of each other in 2006.

All Levels of Strategic Interaction

Strategic interaction could be found at all levels of the market. Sony and Toshiba engaged in fierce price competition for the disk players, with prices in some cases falling near or even below marginal cost. They also raced to sign exclusive contracts with major

¹M. Williams, "HD DVD vs. Blu-Ray Disc: A History," *PC World* online edition, February 2008, <http://www.pcworld.com/article/id,142584-c,dvddrivesmedia/article.html>, accessed on October 6, 2008.

movie studios (Disney signing on to the Blu-Ray format and Paramount to HD-DVD) and major retailers (Blockbuster agreeing to rent only Blu-Rays disks and Wal-Mart lending support to HD-DVD).

There was also a web of strategic interactions among studios, retailers, and consumers. A consumer's benefit from a player increases in the number of other consumers who also have a player using the same format. The more consumers in a format, the more movies will be released in that format and the more opportunities to trade movies with friends. This benefit, which arises with many goods including telephones, computer software, and even social networking Web sites, has been called a *network externality* by economists, capturing the idea that the value of being part of a network is greater the more members the network has. There is also a strategic link between movie studios and consumers because studios benefit from releasing their movies in the most popular format, and as mentioned, consumers like to have the player that has the most movies available in that format.

Game among Consumers

To simplify the analysis, let's abstract away from the full web of strategic interactions and focus just on the game between two representative consumers shown in Table 1. The game has two pure-strategy Nash equilibria—in which the consumers coordinate on a single standard—and the mixed-strategy Nash equilibrium in which consumers randomize with equal probabilities over the two formats, providing each with an expected payoff of $\frac{1}{2}$. The initial play of the game is probably best captured by the mixed-strategy equilibrium. Consumers did not succeed in coordinating; with neither standard dominating, payoffs remained low as little content was provided for in high definition, and what content there was divided

that he will choose Boxing even if his wife chooses Ballet. This threat is sufficient to deter her from choosing Ballet. Given she chooses Boxing in equilibrium, his strategy earns him 2, which is the best he can do in any outcome. So the outcome is a Nash equilibrium. But the husband's strategy involves an empty threat. If the

TABLE 1

High-Definition Standards Game

		Consumer B	
		Blue-Ray	HD-DVD
Consumer A	Blue-Ray	1, 1	0, 0
	HD-DVD	0, 0	1, 1

between the two formats. The difficulty in predicting how even this simple game would be played reflects the difficulty in predicting which firm would win the standards war.

Blu-Ray Emerges Victorious

In February 2008, Toshiba announced that it would stop backing the HD-DVD standard, signaling Sony’s victory with Blu-Ray. Commentators have offered a variety of explanations for this victory. One of the more convincing is that Sony had a huge head start in developing an installed base of consumers by essentially packaging a free Blu-Ray player in every one of the millions of Playstation 3 video-game consoles it sold. Toshiba did not have its own game console; it sought a deal to bundle HD-DVD with Microsoft’s Xbox, only succeeding in having it offered as an expensive add-on.

Table 2 shows how the game might change if A receives a free Blu-Ray player with his or her Playstation. This is modeled as a one-unit increase in A’s payoff from Blu-Ray because this strategy no longer requires the purchase of an expensive machine. The players coordinate even if A chooses HD-DVD and B

TABLE 2

After Packaging Blu-Ray Player in Consumer A’s PS3

		Consumer B	
		Blue-Ray	HD-DVD
Consumer A	Blue-Ray	2, 1	1, 0
	HD-DVD	1, 1	1, 1

chooses Blu-Ray because A can play Blu-Ray disks on his or her Playstation. The reader can show that the two pure-strategy Nash equilibria remain, but the mixed-strategy one has been eliminated. Both consumers playing Blu-Ray is probably the more plausible equilibrium because consumers are as well or better off in that outcome as any other and the outcome can be argued to be focal.

TO THINK ABOUT

1. Think of several other standards wars that have occurred in history, at least one involving media formats and another not. Can you identify factors determining the winning standard?
2. We claimed that Nash equilibria tend to come in odd numbers, yet Table 2 has an even number. This seeming contradiction can be resolved with more precision: Nash equilibria will come in odd numbers unless there are ties between payoffs in rows or columns. Show that an odd number of Nash equilibria result in Table 2 if some of the payoffs are tweaked to break ties.

wife really were to choose Ballet first, he would be giving up a payoff of 1 by choosing Boxing rather than Ballet. It is clear why he would want to threaten to choose Boxing, but it is not clear that such a threat should be believed. Similarly, the husband’s strategy, “Ballet | Ballet, Ballet | Boxing,” in the first Nash equilibrium

Micro Quiz 5.3

Refer to the normal form of the sequential Battle of the Sexes.

1. Provide examples in which referring to equilibria using payoffs is ambiguous but with strategies is unambiguous.
2. Explain why “Boxing” or “Ballet” is not a complete description of the second-mover’s strategy.

Proper subgame

Part of the game tree including an initial decision not connected to another in an oval and everything branching out below it.

Subgame-perfect equilibrium

Strategies that form a Nash equilibrium on every proper subgame.

also involves an empty threat, the threat that he will choose Ballet if his wife chooses Boxing. (This is an odd threat to make since he does not gain from making it, but it is an empty threat nonetheless.)

Subgame-Perfect Equilibrium

Game theory offers a formal way of selecting the reasonable Nash equilibria in sequential games using the concept of subgame-perfect equilibrium. Subgame-perfect equilibrium rules out empty threats by requiring strategies to be rational even for contingencies that do not arise in equilibrium.

Before defining subgame-perfect equilibrium formally, we need to say what a subgame is. A

subgame is a part of the extensive form beginning with a decision point and including everything that branches out below it. A subgame is said to be **proper** if its topmost decision point is not connected to another in the same oval. Conceptually, this means that the player who moves first in a proper subgame knows the actions played by others that have led up to that point. It is easier to see what a proper subgame is than to define it in words. Figure 5.6 shows the extensive forms from the simultaneous and sequential versions of the Battle of the Sexes, with dotted lines drawn around the proper subgames in each. In the simultaneous Battle of the Sexes, there is only one decision point that is not connected to another in an oval, the initial one. Therefore, there is only one proper subgame, the game itself. In the sequential Battle of the Sexes, there are three proper subgames: the game itself, and two lower subgames starting with decision points where the husband gets to move.

A **subgame-perfect equilibrium** is a set of strategies, one for each player, that form a Nash equilibrium on every proper subgame. A subgame-perfect equilibrium is always a Nash equilibrium. This is true since the whole game is a proper subgame of itself, so a subgame-perfect equilibrium must be a Nash equilibrium on the whole

TABLE 5.8

Husband’s Contingent Strategies

<u>Contingent strategy</u>	<u>Same strategy written in conditional format</u>
Always go to Ballet	Ballet Ballet, Ballet Boxing
Follow his wife	Ballet Ballet, Boxing Boxing
Do the opposite	Boxing Ballet, Ballet Boxing
Always go to Boxing	Boxing Ballet, Boxing Boxing

TABLE 5.9

Sequential Version of the Battle of the Sexes in Normal Form

		B (Husband)			
		Ballet Ballet	Ballet Boxing	Boxing Ballet	Boxing Boxing
A (Wife)	Ballet	2, 1	2, 1	0, 0	0, 0
	Boxing	0, 0	1, 2	0, 0	1, 2

game. In the simultaneous version of the Battle of the Sexes, there is nothing more to say since there are no other subgames besides the whole game itself.

In the sequential version of the Battle of the Sexes, the concept of subgame-perfect equilibrium has more bite. In addition to constituting a Nash equilibrium on the whole game, strategies must constitute Nash equilibria on the two other proper

FIGURE 5.5

Sequential Version of the Battle of the Sexes in Extensive Form

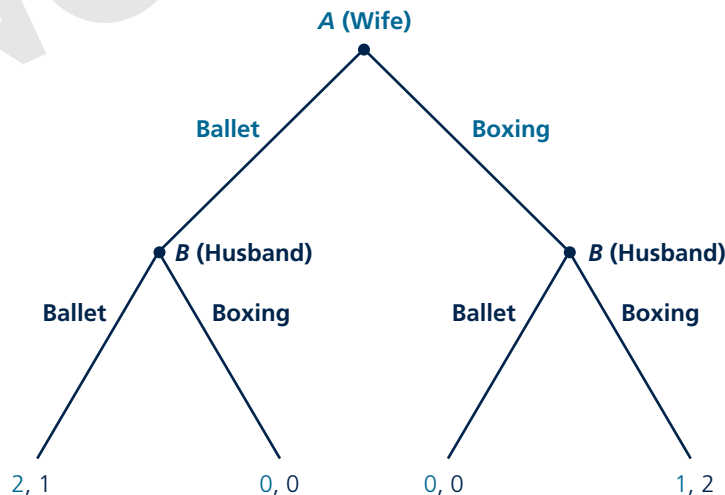

TABLE 5.10

Solving for Nash Equilibria in the Sequential Version of the Battle of the Sexes

		B (Husband)			
		Ballet Ballet Ballet Boxing	Ballet Ballet Boxing Boxing	Boxing Ballet Ballet Boxing	Boxing Ballet Boxing Boxing
A (Wife)	Ballet	Nash equilibrium 1 <u>2</u> , <u>1</u>	Nash equilibrium 2 <u>2</u> , <u>1</u>	<u>0</u> , 0	0, 0
	Boxing	0, 0	1, <u>2</u>	<u>0</u> , 0	Nash equilibrium 3 <u>1</u> , <u>2</u>

subgames. These subgames are simple decision problems, and so it is easy to compute the corresponding Nash equilibria. In the left-hand subgame, following his wife's choosing Ballet, the husband has a simple decision between Ballet, which earns him a payoff of 1, and Boxing, which earns him a payoff of 0. The Nash equilibrium in this subgame is for the husband to choose Ballet. In the right-hand subgame, following his wife's choosing Boxing, he has a simple decision between Ballet, which earns him 0, and Boxing, which earns him 2. The Nash equilibrium in this subgame is for him to choose Boxing. Thus we see that the husband has only one strategy that can be part of a subgame-perfect equilibrium: "Ballet | Ballet, Boxing | Boxing." Any other strategy has him playing something that is not a Nash equilibrium on some proper subgame. Returning to the three enumerated Nash equilibria, only the second one is subgame-perfect. The first and the third are not. For example, the third equilibrium, in which the husband always goes to Boxing, is ruled out as a subgame-perfect equilibrium because the husband would not go to Boxing if the wife indeed went to Ballet; he would go to Ballet as well. Subgame-perfect equilibrium thus rules out the empty threat of always going to Boxing that we were uncomfortable with in the previous section.

More generally, subgame-perfect equilibrium rules out any sort of empty threat in any sequential game. In effect, Nash equilibrium only requires behavior to be rational on the part of the game tree that is reached in equilibrium. Players can choose potentially irrational actions on other parts of the game tree. In particular, a player can threaten to damage both of them in order to "scare" the other from choosing certain actions. Subgame-perfect equilibrium requires rational behavior on all parts of the game tree. Threats to play irrationally, that is, threats to choose something other than one's best response, are ruled out as being empty.

FIGURE 5.6 Proper Subgames in the Battle of the Sexes

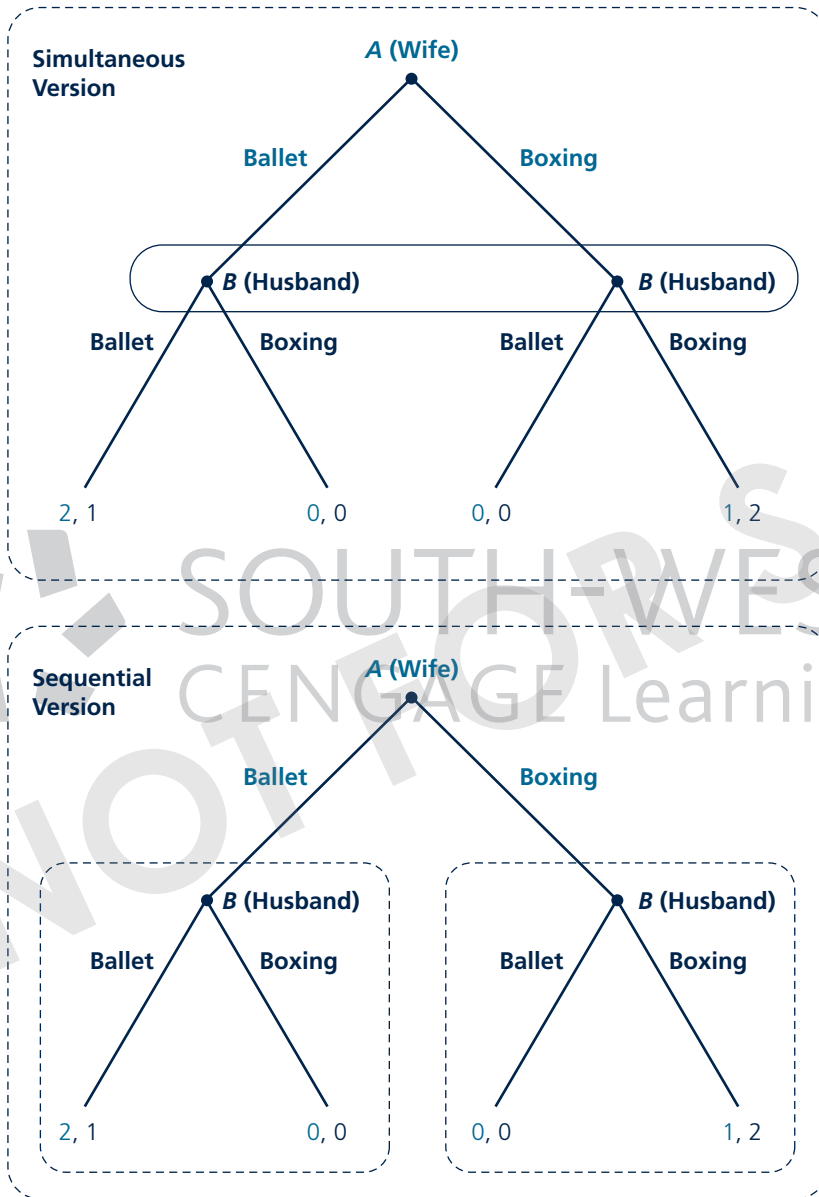

Subgame-perfect equilibrium does not reduce the number of Nash equilibria in a simultaneous game because a simultaneous game has no proper subgames other than the game itself.

Backward induction

Solving for equilibrium by working backwards from the end of the game to the beginning.

Backward Induction

Our approach to solving for the equilibrium in the sequential Battle of the Sexes was to find all the Nash equilibria using the normal form, and then to sort through them for the subgame-perfect equilibrium. A shortcut to find the subgame-perfect equilibrium directly is to use **backward induction**. Backward induction works as follows: identify all of the subgames at the bottom of the extensive form; find the Nash equilibria on these subgames; replace the (potentially complicated) subgames with the actions and payoffs resulting from Nash equilibrium play on these subgames; then move up to the next level of subgames and repeat the procedure.

Figure 5.7 illustrates the use of backward induction to solve for the subgame-perfect equilibrium of the sequential Battle of the Sexes. First compute the Nash equilibria of the bottom-most subgames, in this case the subgames corresponding to the husband's decision problems. In the subgame following his wife's choosing Ballet, he would choose Ballet, giving payoffs 2 for her and 1 for him. In the subgame following his wife's choosing Boxing, he would choose Boxing, giving payoffs 1 for her and 2 for him. Next, substitute the husband's equilibrium strategies for the subgames themselves. The resulting game is a simple decision problem for the wife, drawn in the lower panel of the figure, a choice between Ballet, which would give her a payoff of 2 and Boxing, which would give her a payoff of 1. The Nash equilibrium of this game is for her to choose the action with the higher payoff, Ballet. In sum, backward induction allows us to jump straight to the subgame-perfect equilibrium, in which the wife chooses Ballet and the husband chooses "Ballet | Ballet, Boxing | Boxing," and bypass the other Nash equilibria.

Backward induction is particularly useful in games in which there are many rounds of sequential play. As rounds are added, it quickly becomes too hard to solve for all the Nash equilibria and then to sort through which are subgame-perfect. With backward induction, an additional round is simply accommodated by adding another iteration of the procedure.

Application 5.4: Laboratory Experiments discusses whether human subjects play games the way theory predicts in experimental settings, including whether subjects play the subgame-perfect equilibrium in sequential games.

Repeated Games

So far, we have examined one-shot games in which each player is given one choice and the game ends. In many real-world settings, the same players play the same **stage game** several or even many times. For example, the players in the Prisoners' Dilemma may anticipate committing future crimes together and thus playing future Prisoners' Dilemmas together. Gas stations located across the street from each other, when they set their prices each morning, effectively play a new pricing game every day.

As we saw with the Prisoners' Dilemma, when such games are played once, the equilibrium outcome may be worse for all players than some other, more cooperative, outcome. Repetition opens up the possibility of the cooperative outcome being played in equilibrium. Players can adopt **trigger strategies**, whereby they play the cooperative outcome as long as all have cooperated up to that point, but revert to

Stage game

Simple game that is played repeatedly.

Trigger strategy

Strategy in a repeated game where the player stops cooperating in order to punish another player's break with cooperation.

FIGURE 5.7

Backward Induction in the Sequential Battle of the Sexes

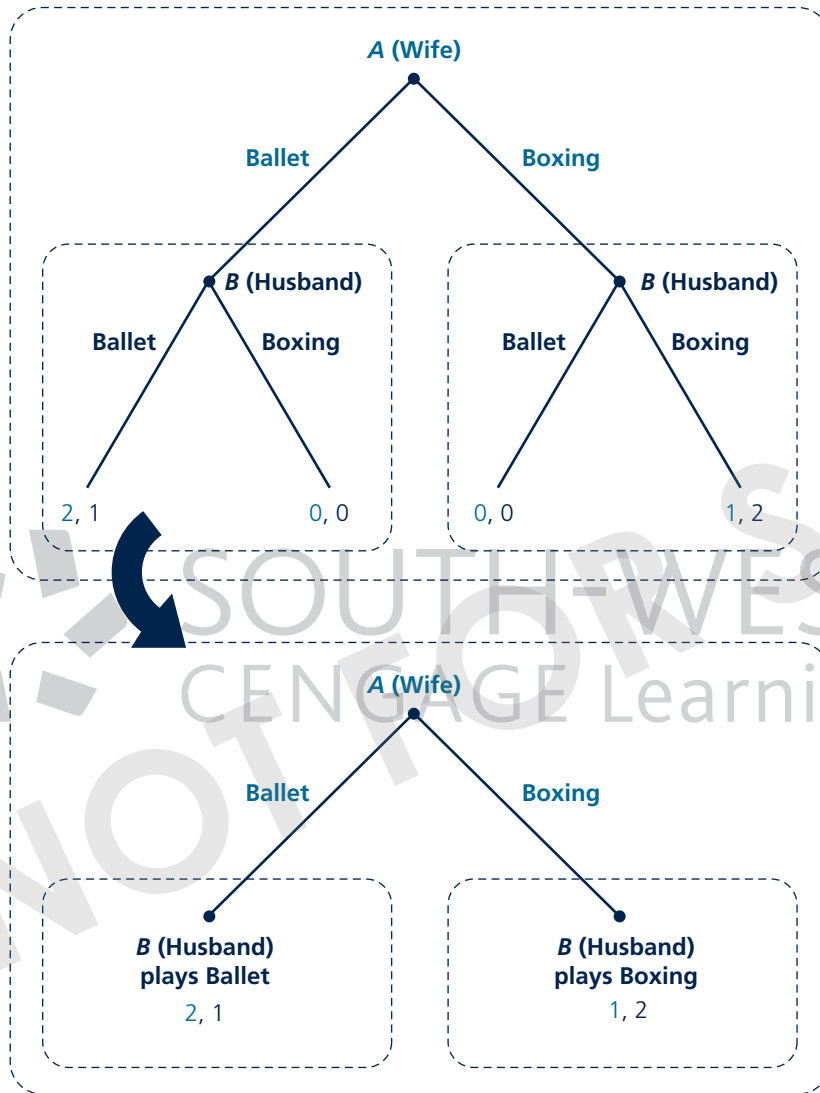

playing the Nash equilibrium if anyone breaks with cooperation. We will investigate the conditions under which trigger strategies work to increase players' payoffs. We will focus on subgame-perfect equilibria of the repeated games.

Definite Time Horizon

For many stage games, repeating them a known, finite number of times does not increase the possibility for cooperation. To see this point concretely, suppose the

A P P L I C A T I O N 5.4

Laboratory Experiments

Experimental economics tests how well economic theory matches the behavior of experimental subjects in laboratory settings. The methods are similar to those used in experimental psychology—often conducted on campus using undergraduates as subjects—the main difference being that experiments in economics tend to involve incentives in the form of explicit monetary payments paid to subjects. The importance of experimental economics was highlighted in 2002, when Vernon Smith received the Nobel prize in economics for his pioneering work in the field.

Prisoners' Dilemma

There have been hundreds of tests of whether players Confess in the Prisoners' Dilemma, as predicted by Nash equilibrium, or whether they play the cooperative outcome of Silent. In the experiments of Cooper et al.,¹ subjects played the game 20 times, against different, anonymous opponents. Play converged to the Nash equilibrium as subjects gained experience with the game. Players played the coop-

¹R. Cooper, D. V. DeJong, R. Forsythe, and T. W. Ross, "Cooperation Without Reputation: Experimental Evidence from Prisoner's Dilemma Games," *Games and Economic Behavior* (February 1996): 187–218.

erative action 43 percent of the time in the first five rounds, falling to only 20 percent of the time in the last five rounds.

Ultimatum Game

Experimental economics has also tested to see whether subgame-perfect equilibrium is a good predictor of behavior in sequential games. In one widely studied sequential game, the Ultimatum Game, the experimenter provides a pot of money to two players. The first mover (Proposer) proposes a split of this pot to the second mover. The second mover (Responder) then decides whether to accept the offer, in which case players are given the amount of money indicated, or reject the offer, in which case both players get nothing. As one can see by using backward induction, in the subgame-perfect equilibrium, the Proposer should offer a minimal share of the pot and this should be accepted by the Responder.

In experiments, the division tends to be much more even than in the subgame-perfect equilibrium.²

²For a review of Ultimatum Game experiments and a textbook treatment of experimental economics more generally, see D. D. Davis and C. A. Holt, *Experimental Economics* (Princeton: Princeton University Press, 1993).

Prisoners' Dilemma were repeated for 10 periods. Use backward induction to solve for the subgame-perfect equilibrium. The lowest subgame is the one-shot Prisoners' Dilemma played in the 10th period. Regardless of what happened before, the Nash equilibrium on this subgame is for both to play Confess. Folding the game back to the ninth period, trigger strategies that condition play in the 10th period on what happens in the ninth are ruled out. Nothing that happens in the ninth period affects what happens subsequently because, as we just argued, the players both Confess in the 10th period no matter what. It is as if the ninth period is the last, and again the Nash equilibrium on this subgame is again for both to play Confess. Working backward in this way, we see that players will Confess each period; that is, players will simply repeat the Nash equilibrium of the stage game 10 times. The same argument would apply for any definite number of repetitions.

The most common offer is a 50–50 split. Responders tend to reject offers giving them less than 30 percent of the pot. This result is observed even when the pot is as high as \$100, so that rejecting a 30 percent offer means turning down \$30. Some economists have suggested that money may not be a true measure of players' payoffs, which may include other factors such as how fairly the pot is divided.³ Even if a Proposer does not care directly about fairness, the fear that the Responder may care about fairness and thus might reject an uneven offer out of spite may lead the Proposer to propose an even split.

Dictator Game

To test whether players care directly about fairness or act out of fear of the other player's spite, researchers experimented with a related game, the Dictator Game. In the Dictator Game, the Proposer chooses a split of the pot, and this split is implemented without input from the Responder. Proposers tend to offer a less-even split than in the Ultimatum Game, but still offer the Responder some of the pot, suggesting Responders had some residual concern for fairness. The details

³See, for example, M. Rabin, "Incorporating Fairness into Game Theory and Economics," *American Economic Review* (December 1993): 1281–1302.

of the experimental design are crucial, however, as one ingenious experiment showed.⁴ The experiment was designed so that the experimenter would never learn which Proposers had made which offers. With this element of anonymity, Proposers almost never gave an equal split to Responders and, indeed, took the whole pot for themselves two-thirds of the time. The results suggest that Proposers care more about being thought of as fair rather than truly being fair.

TO THINK ABOUT

1. As an experimenter, how would you choose the following aspects of experimental design? Are there any tradeoffs involved?
 - a. Size of the payoffs.
 - b. Ability of subjects to see opponents.
 - c. Playing the same game against the same opponent repeatedly.
 - d. Informing subjects fully about the experimental design.
2. How would you construct an experiment involving the Battle of the Sexes? What theoretical issues might be interesting to test with your experiment?

⁴E. Hoffman, K. McCabe, K. Shachat, and V. Smith, "Preferences, Property Rights, and Anonymity in Bargaining Games," *Games and Economic Behavior* (November 1994): 346–380.

Indefinite Time Horizon

If the number of times the stage game is repeated is indefinite, matters change significantly. The number of repetitions is indefinite if players know the stage game will be repeated but are uncertain of exactly how many times. For example, the partners in crime in the Prisoners' Dilemma may know that they will participate in many future crimes together, sometimes be caught, and thus have to play the Prisoners' Dilemma game against each other, but may not know exactly how many opportunities for crime they will have or how often they will be caught. With an indefinite number of repetitions, there is no final period from which to start applying backward induction, and thus no final period for trigger strategies to begin unraveling. Under certain conditions, more cooperation can be sustained than in the stage game.

Suppose the two players play the following repeated version of the Prisoners' Dilemma. The game is played in the first period for certain, but for how many more periods after that the game is played is uncertain. Let g be the probability the game is repeated for another period and $1-g$ the probability the repetitions stop for good. Thus, the probability the game lasts at least one period is 1, at least two periods is g , at least three periods is g^2 , and so forth.

Suppose players use the trigger strategies of playing the cooperative action, Silent, as long as no one cheats by playing Confess, but that players both play Confess forever afterward if either of them had ever cheated. To show that such strategies constitute a subgame-perfect equilibrium, we need to check that a player cannot gain by cheating. In equilibrium, both players play Silent and each earns -2 each period the game is played, implying a player's expected payoff over the course of the entire game is

$$(-2)(1 + g + g^2 + g^3 + \dots). \quad (5.1)$$

If a player cheats and plays Confess, given the other is playing Silent, the cheater earns -1 in that period, but then both play Confess every period, from then on, each earning -3 each period, for a total expected payoff of

$$-1 + (-3)(g + g^2 + g^3 + \dots). \quad (5.2)$$

For cooperation to be a subgame-perfect equilibrium, (5.1) must exceed (5.2). Adding 2 to both expressions, and then adding $3(g + g^2 + g^3 + \dots)$ to both expressions, (5.1) exceeds (5.2) if

$$g + g^2 + g^3 + \dots > 1. \quad (5.3)$$

To proceed further, we need to find a simple expression for the series $g + g^2 + g^3 + \dots$. A standard mathematical result is that the series $g + g^2 + g^3 + \dots$ equals $g/(1-g)$.⁴ Substituting this result in (5.3), we see that (5.3) holds, and so cooperation on Silent can be sustained, if g is greater than $1/2$.⁵

This result means that players can cooperate in the repeated Prisoners' Dilemma only if the probability of repetition g is high enough. Players are tempted to cheat on the cooperative equilibrium, obtaining a short-run gain (-1 other than -2) by Confessing. The threat of the loss of future gains from cooperating deters cheating. This threat only works if the probability the game is continued into the future is high enough.

Other strategies can be used to try to elicit cooperation in the repeated game. We considered strategies that had players revert to the Nash equilibrium of Confess each period forever. This strategy, which involves the harshest possible punishment for deviation, is called the grim strategy. Less harsh punishments include the so-called tit-for-tat strategy, which involves only one round of

⁴Let $S = g + g^2 + g^3 + \dots$. Multiplying both sides by g , $gS = g^2 + g^3 + g^4 + \dots$. Subtracting gS from S , we have $S - gS = (g + g^2 + g^3 + \dots) - (g^2 + g^3 + g^4 + \dots) = g$ because all of the terms on the right-hand side cancel except for the leading g . Thus $(1-g)S = g$, or, rearranging, $S = g/(1-g)$.

⁵The mathematics are the same in an alternative version of the game in which the stage game is repeated with certainty each period for an infinite number of periods, but in which future payoffs are discounted according to a per-period interest rate. One can show that cooperation is possible if the per-period interest rate is less than 100 percent.

punishment for cheating. Since it involves the harshest punishment possible, the grim strategy elicits cooperation for the largest range of cases (the lowest value of g) of any strategy. Harsh punishments work well because, if players succeed in cooperating, they never experience the losses from the punishment in equilibrium. If there were uncertainty about the economic environment, or about the rationality of the other player, the grim strategy may not lead to as high payoffs as less-harsh strategies.

One might ask whether the threat to punish the other player (whether forever as in the grim strategy or for one round with tit-for-tat) is an empty threat since punishment harms both players. The answer is no. The punishment involves reverting to the Nash equilibrium, in which both players choose best responses, and so it is a credible threat and is consistent with subgame-perfect equilibrium.

Micro Quiz 5.4

Consider the indefinitely repeated Prisoners' Dilemma.

1. For what value of g does the repeated game become simply the stage game?
2. Suppose at some point while playing the grim strategy, players relent and go back to the cooperative outcome (Silent). If this relenting were anticipated, how would it affect the ability to sustain the cooperative outcome?

CONTINUOUS ACTIONS

Most of the insight from economic situations can often be gained by distilling the situation down to a game with two actions, as with all of the games studied so far. Other times, additional insight can be gained by allowing more actions, sometimes even a continuum. Firms' pricing, output or investment decisions, bids in auctions, and so forth are often modeled by allowing players a continuum of actions. Such games can no longer be represented in the normal form we are used to seeing in this chapter, and the underlining method cannot be used to solve for Nash equilibrium. Still, the new techniques for solving for Nash equilibria will have the same logic as those seen so far. We will illustrate the new techniques in a game called the Tragedy of the Commons.

Tragedy of the Commons

The game involves two shepherds, A and B , who graze their sheep on a common (land that can be freely used by community members). Let s_A and s_B be the number of sheep each grazes, chosen simultaneously. Because the common only has a limited amount of space, if more sheep graze, there is less grass for each one, and they grow less quickly. To be concrete, suppose the benefit A gets from each sheep (in terms of mutton and wool) equals

$$120 - s_A - s_B. \quad (5.4)$$

The total benefit A gets from a flock of s_A sheep is therefore

$$s_A(120 - s_A - s_B). \quad (5.5)$$

Although we cannot use the method of underlining payoffs for best responses, we can compute A 's best-response function. Recall the use of best-response

FIGURE 5.8

Best-Response Functions
in the Tragedy of the
Commons

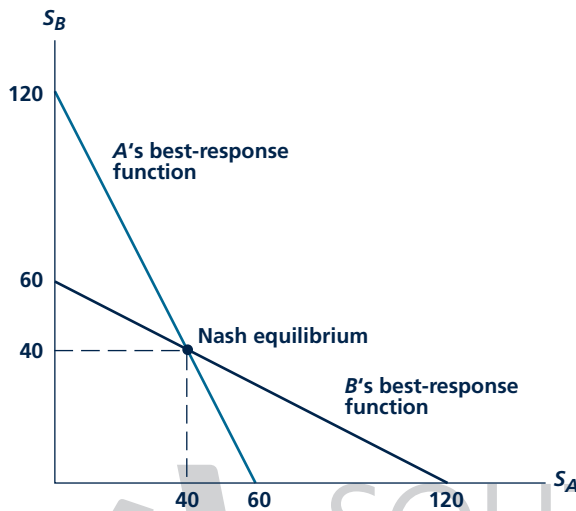

functions in computing the mixed-strategy Nash equilibrium in the Battle of the Sexes game. We resorted to best-response functions because, although the Battle of the Sexes game has only two actions, there is a continuum of possible mixed strategies over those two actions. In the Tragedy of the Commons here, we need to resort to best-response functions because we start off with a continuum of actions.

A's best-response function gives the s_A that maximizes A's payoff for any s_B . A's best response will be the number of sheep such that the marginal benefit of an additional sheep equals the marginal cost. His marginal benefit of an additional sheep is⁶

$$120 - 2s_A - s_B. \quad (5.6)$$

The total cost of grazing sheep is 0 since they graze freely on the common, and so the marginal cost of an additional sheep is also 0. Equating the marginal benefit in (5.6) with the marginal cost of 0 and solving for s_A , A's best-response function equals

$$s_A = 60 - \frac{s_B}{2}. \quad (5.7)$$

By symmetry, B's best-response function is

$$s_B = 60 - \frac{s_A}{2}. \quad (5.8)$$

For actions to form a Nash equilibrium, they must be best responses to each other; in other words, they must be the simultaneous solution to (5.7) and (5.8). The simultaneous solution is shown graphically in Figure 5.8. The best-response functions are graphed with s_A on the horizontal axis and s_B on the vertical (the inverse of A's best-response function is actually what is graphed). The Nash equilibrium, which lies at the intersection of the two functions, involves each grazing 40 sheep.

The game is called a tragedy because the shepherds end up overgrazing in equilibrium. They overgraze because they do not take into account the reduction in the value of other's sheep when they choose the size of their flocks. If each grazed 30 rather than 40 sheep, one can show that each would earn a total payoff of 1,800 rather than the 1,600 they each earn in equilibrium. Over-consumption is a typical finding in settings where multiple parties have free access to a common resource, such as multiple wells pumping oil from a common underground pool or multiple fishing boats fishing in the same ocean area, and is often a reason given for

⁶One can take the formula for the marginal benefit in (5.6) as given or can use calculus to verify it. Differentiating the benefit function (5.5), which can be rewritten $120s_A - s_A^2 - s_A s_B$, term by term with respect to s_A (treating s_B as a constant) yields the marginal benefit (5.6).

restricting access to such common resources through licensing and other government interventions.

Shifting Equilibria

One reason it is useful to allow players to have continuous actions is that it is easier in this setting to analyze how a small change in one of the game's parameters shifts the equilibrium. For example, suppose A 's benefit per sheep rises from (5.4) to

$$132 - 2s_A - s_B \quad (5.9)$$

A 's best-response function becomes

$$s_A = 66 - \frac{s_B}{2} \quad (5.10)$$

B 's stays the same as in (5.8). As shown in Figure 5.9, in the new Nash equilibrium, A increases his flock to 48 sheep and B decreases his to 36. It is clear why the size of A 's flock increases: the increase in A 's benefit shifts his best-response function out. The interesting strategic effect is that—while nothing about B 's benefit has changed, and so B 's best-response function remains the same as before—having observed A 's benefit increasing from (5.4) to (5.9), B anticipates that it must choose a best response to a higher quantity by A , and so ends up reducing the size of his flock.

Games with continuous actions offer additional insights in other contexts, as shown in Application 5.5: Terrorism.

N-PLAYER GAMES

Just as we can often capture the essence of a situation using a game with two actions, as we have seen with all the games studied so far, we can often distill the number of players down to two as well. However in some cases, it is useful to study games with more than two players. This is particularly useful to answer the question of how a change in the number of players would affect the equilibrium (see, for example, MicroQuiz 5.5). The problems at the end of the chapter will provide some examples of how to draw the normal form in games with more than two players.

FIGURE 5.9

Shift in Equilibrium When A 's Benefit Increases

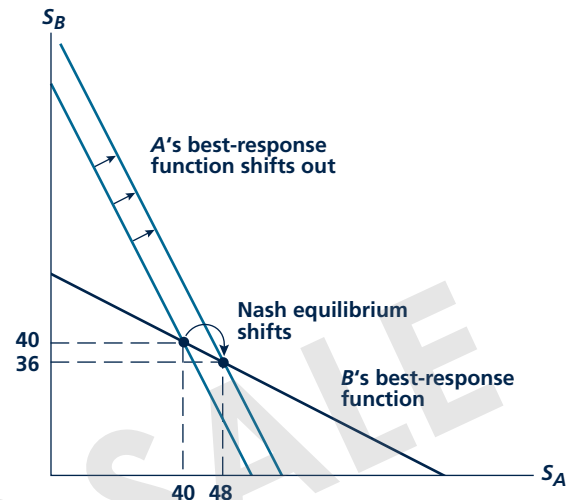

An increase in A 's benefit per sheep shifts his best-response function out. Though B 's best-response function remains the same, his equilibrium number of sheep falls in the new Nash equilibrium.

Micro Quiz 5.5

Suppose the Tragedy of the Commons involved three shepherds (A , B , and C). Suppose the benefit per sheep is $120 - s_A - s_B - s_C$, implying that, for example, A 's total benefit is $s_A(120 - s_A - s_B - s_C)$ and marginal benefit is $120 - 2s_A - s_B - s_C$.

1. Solve the three equations that come from equating each of the three shepherds' marginal benefit of a sheep to the marginal cost (zero) to find the Nash equilibrium.
2. Compare the total number of sheep on the common with three shepherds to that with two.

A P P L I C A T I O N 5.5

Terrorism

Few issues raise as much public-policy concern as terrorism, given the continued attacks in the Middle East and Europe and the devastating attack on the World Trade Center and Pentagon in the United States on September 11, 2001. In this application, we will see that game theory can be usefully applied to analyze terrorism and the best defensive measures against it.

Defending Targets against Terrorism

Consider a sequential game between a government and a terrorist. The players have the opposite objectives: the government wants to minimize the expected damage from terrorism, and the terrorist wants to maximize expected damage. For simplicity, assume the terrorist can attack one of two targets: target 1 (say a nuclear power plant) leads to considerable damage if successfully attacked; target 2 (say a restaurant) leads to less damage. The government moves first, choosing s_1 , the proportion of its security force guarding target 1. The remainder of the security force, $1 - s_1$, guards target 2. (Note that the government's action is a continuous variable between 0 and 1, so this is an application of our general discussion of games with continuous actions in the text.) The

terrorist moves second, choosing which target to attack. Assume the probability of successful attack on target 1 is $1 - s_1$ and on target 2 is s_1 , implying that the larger the security force guarding a particular target, the lower the probability of a successful attack.

To solve for the subgame-perfect equilibrium, we will apply backward induction, meaning in this context that we will consider the terrorist's (the second-mover's) decision first. The terrorist will compute the expected damage from attacking each target, equal to the probability of a successful attack multiplied by the damage caused if the attack is successful. The terrorist will attack the target with the highest expected damage. Moving backward to the first mover's (the government's) decision, the way for the government to minimize the expected damage from terrorism is to divide the security force between the two targets so that the expected damage is equalized. (Suppose the expected damage from attacking target 1 were strictly higher than target 2. Then the terrorist would definitely attack target 1, and the government could reduce expected damage from this attack by shifting some of the security force from target 2 to target 1.) Using some numbers, if the damage from a successful attack on target 1 is

INCOMPLETE INFORMATION

In all the games studied so far, there was no private information. All players knew everything there was to know about each others' payoffs, available actions, and so forth. Matters become more complicated, and potentially more interesting, if players know something about themselves that others do not know. For example, one's bidding strategy in a sealed-bid auction for a painting would be quite different if one knew the valuation of everyone else at the auction compared to the (more realistic) case in which one did not. Card games would be quite different, certainly not as fun, if all hands were played face up. Games in which players do not share all relevant information in common are called games of **incomplete information**.

We will devote most of Chapter 17 to studying games of incomplete information. We will study signaling games, which include students choosing how much education to obtain in order to signal their underlying aptitude, which might be

Incomplete information

Some players have information about the game that others do not.

10 times that on target 2, the government should put 10 times the security force on target 1. The terrorist ends up playing a mixed strategy in equilibrium, with each target having a positive probability of being attacked.

Bargaining with Terrorists

Terrorism raises many more issues than those analyzed above. Suppose terrorists have taken hostages and demand the release of prisoners in return for the hostages' freedom. Should a country bargain with the terrorists?¹ The official policy of countries, including the United States and Israel, is no. Using backward induction, it is easy to see why countries would like to commit not to bargain because this would preclude any benefit from taking hostages and deter the terrorists from taking hostages in the first place. But a country's commitment to not bargain may not be credible, especially if the hostages are "important" enough, as was the case when the Israeli parliament voted to bargain for the release of 21 students taken hostage in a high school in Maalot, Israel, in 1974. (The vote came after the deadline set by the terrorists, and the students ended up being killed.) The

¹See H. E. Lapan and T. Sandler, "To Bargain or not to Bargain: That Is the Question," *American Economic Review* (May 1988): 16–20.

country's commitment may still be credible in some scenarios. If hostage incidents are expected to arise over time repeatedly, the country may refuse to bargain as part of a long-term strategy to establish a reputation for not bargaining. Another possibility is that the country may not trust the terrorists to free the hostages after the prisoners are released, in which case there would be little benefit from bargaining with them.

TO THINK ABOUT

1. The U.S. government has considered analyzing banking transactions to look for large, suspicious movements of cash as a screen for terrorists. What are the pros and cons of such a screen? How would the terrorists respond in equilibrium if they learned of this screen? Would it still be a useful tool?
2. Is it sensible to model the terrorist as wanting to maximize expected damage? Instead, the terrorist may prefer to attack "high-visibility" targets, even if this means lower expected damage, or may prefer to maximize the sum of damage plus defense/deterrence expenditures. Which alternative is most plausible? How would these alternatives affect the game?

difficult to observe directly, to prospective employers. We will study screening games, which include the design of deductible policies by insurance companies in order to deter high-risk consumers from purchasing. As mentioned, auctions and card games also fall in the realm of games of incomplete information. Such games are at the forefront of current research in game theory.

SUMMARY

This chapter provided a brief overview of game theory. Game theory provides an organized way of understanding decision making in strategic environments. We introduced the following broad ideas:

- The basic building blocks of all games are players, actions, payoffs, and information.

- Nash equilibrium is the most widely used equilibrium concept. Strategies form a Nash equilibrium if all players' strategies are best responses to each other. All games have at least one Nash equilibrium. Sometimes the Nash equilibrium is in mixed strategies, which we learned how to

compute. Some games have multiple Nash equilibria, and it may be difficult in these cases to make predictions about which one will end up being played.

- We studied several classic games, including the Prisoners' Dilemma, Matching Pennies, and Battle of the Sexes. These games each demonstrated important principles. Many strategic situations can be distilled down to one of these games.
- Sequential games introduce the possibility of contingent strategies for the second mover and often

expand the set of Nash equilibria. Subgame-perfect equilibrium rules out outcomes involving empty threats. One can easily solve for subgame-perfect equilibrium using backward induction.

- In some games such as the Prisoners' Dilemma, all players are worse off in the Nash equilibrium than in some other outcome. If the game is repeated an indefinite number of times, players can use trigger strategies to try to enforce the better outcome.

REVIEW QUESTIONS

1. In game theory, players maximize payoffs. Is this assumption different from the one we used in Chapters 2 and 3?
2. What is the difference between an action and a strategy?
3. Why are Nash equilibria identified by the strategies rather than the payoffs involved?
4. Which of the following activities might be represented as a zero-sum game? Which are clearly not zero-sum?
 - a. Flipping a coin for \$1.
 - b. Playing blackjack.
 - c. Choosing which candy bar to buy from a vendor.
 - d. Reducing taxes through various "creative accounting" methods and seeking to avoid detection by the IRS.
 - e. Deciding when to rob a particular house, knowing that the residents may adopt various countertheft strategies.
5. Why is the Prisoners' Dilemma a "dilemma" for the players involved? How might they solve this dilemma through pregame discussions or postgame threats? If you were arrested and the D.A. tried this ploy, what would you do? Would it matter whether you were very close friends with your criminal accomplice?
6. The Battle of the Sexes is a coordination game. What coordination games arise in your experience? How do you go about solving coordination problems?
7. In the sequential games such as the sequential Battle of the Sexes, why does Nash equilibrium allow for outcomes with noncredible threats? Why does subgame-perfect equilibrium rule them out?
8. Which of these relationships would be better modeled as involving repetitions and which not, or does it depend? For those that are repeated, which are more realistically seen as involving a definite number of repetitions and which an indefinite number?
 - a. Two nearby gas stations posting their prices each morning.
 - b. A professor testing students in a course.
 - c. Students entering a dorm room lottery together.
 - d. Accomplices committing a crime.
 - e. Two lions fighting for a mate.
9. In the Tragedy of the Commons, we saw how a small change in A 's benefit resulted in a shift in A 's best response function and a movement along B 's best-response function. Can you think of other factors that might shift A 's best-response function? Relate this discussion to shifts in an individual's demand curve versus movements along it.
10. Choose a setting from student life. Try to model it as a game, with a set number of players, payoffs, and actions. Is it like any of the classic games studied in this chapter?

PROBLEMS

5.1 Consider a simultaneous game in which player A chooses one of two actions (Up or Down), and B chooses one of two actions (Left or Right). The game has the following payoff matrix, where the first payoff in each entry is for A and the second for B .

		B	
		Left	Right
A	Up	3, 3	5, 1
	Down	2, 2	4, 4

- Find the Nash equilibrium or equilibria.
- Which player, if any, has a dominant strategy?

5.2 Suppose A can somehow change the game in problem 5.1 to a new one in which his payoff from Up is reduced by 2, producing the following payoff matrix.

		B	
		Left	Right
A	Up	1, 3	3, 1
	Down	2, 2	4, 4

- Find the Nash equilibrium or equilibria.
- Which player, if any, has a dominant strategy?
- Does A benefit from changing the game by reducing his or her payoff in this way?

5.3 Return to the game given by the payoff matrix in Problem 5.1.

- Write down the extensive form for the simultaneous-move game.
- Suppose the game is now sequential move, with A moving first and then B . Write down the extensive form for this sequential-move game.
- Write down the normal form for the sequential-move game. Find all the Nash equilibria. Which Nash equilibrium is subgame-perfect?

5.4 Consider the war over the new format for high-definition video disks discussed in Application 5.3, but shift the focus to the game (provided in the following table) between the two firms, Sony and Toshiba.

		Toshiba	
		Invest heavily	Slacken
Sony	Invest heavily	0, 0	3, 1
	Slacken	1, 3	2, 2

- Find the pure-strategy Nash equilibrium or equilibria.
- Compute the mixed-strategy Nash equilibrium. As part of your answer, draw the best-response function diagram for the mixed strategies.
- Suppose the game is played sequentially, with Sony moving first. What are Toshiba's contingent strategies? Write down the normal and extensive forms for the sequential version of the game.
- Using the normal form for the sequential version of the game, solve for the Nash equilibria.
- Identify the proper subgames in the extensive form for the sequential version of the game. Use backward induction to solve for the subgame-perfect equilibrium. Explain why the other Nash equilibria of the sequential game are "unreasonable."

5.5 Two classmates A and B are assigned an extra-credit group project. Each student can choose to Shirk or Work. If one or more players chooses Work, the project is completed and provides each with extra credit valued at 4 payoff units each. The cost of completing the project is that 6 total units of effort (measured in payoff units) is divided equally among all players who choose to Work and this is subtracted from their payoff. If both Shirk, they do not have to expend any effort but the project is not completed, giving each a payoff of 0. The teacher can only tell whether the project is completed and not which students contributed to it.

- a. Write down the normal form for this game, assuming students choose to Shirk or Work simultaneously.
- b. Find the Nash equilibrium or equilibria.
- c. Does either player have a dominant strategy? What game from the chapter does this resemble?

5.6 Return to the Battle of the Sexes in Table 5.5. Compute the mixed-strategy Nash equilibrium under the following modifications and compare it to the one computed in the text. Draw the corresponding best-response-function diagram for the mixed strategies.

- a. Double all of the payoffs.
- b. Double the payoff from coordinating on one's preferred activity from 2 to 4 but leave all other payoffs the same.
- c. Change the payoff from choosing one's preferred activity alone (that is, not coordinating with one's spouse) from 0 to 1/2 for each but leave all the other payoffs the same.

5.7 The following game is a version of the Prisoners' Dilemma, but the payoffs are slightly different than in Table 5.1.

		B	
		Confess	Silent
A	Confess	0, 0	3, -1
	Silent	-1, 3	1, 1

- a. Verify that the Nash equilibrium is the usual one for the Prisoners' Dilemma and that both players have dominant strategies.
- b. Suppose the stage game is played an indefinite number of times with a probability g the game is continued to the next stage and $1 - g$ that the game ends for good. Compute the level of g that is required for a subgame-perfect equilibrium in which both players play a trigger strategy where both are Silent if no one deviates but resort to a grim strategy (that is, both play Confess forever after) if anyone deviates to Confess.
- c. Continue to suppose the stage game is played an indefinite number of times, as in b. Is there a value of g for which there exists a subgame-perfect equilibrium in which both players play

a trigger strategy where both are Silent if no one deviates but resort to tit-for-tat (that is, both play Confess for one period and go back to Silent forever after that) if anyone deviates to Confess. Remember that g is a probability so it must be between 0 and 1.

5.8 Find the pure-strategy Nash equilibrium or equilibria of the following game with three actions for each player.

		B		
		Left	Center	Right
A	Up	4, 3	5, -1	6, 2
	Middle	2, 1	7, 4	3, 6
	Down	3, 0	9, 6	0, 8

5.9 Three department stores, A, B, and C, simultaneously decide whether or not to locate in a mall that is being constructed in town. A store likes to have another with it in the mall since then there is a critical mass of stores to induce shoppers to come out. However, with three stores in the mall, there begins to be too much competition among them and store profits fall drastically. Read the payoff matrix as follows: the first payoff in each entry is for A, the second for B, and the third for C; C's choice determines which of the bold boxes the other players find themselves in.

		C Chooses Mall		C Chooses Not Mall	
		B		B	
		Mall	Not Mall	Mall	Not Mall
A	Mall	-2, -2, -2	2, 0, 2	2, 1, 0	-1, 0, 0
	Not Mall	0, 1, 2	0, 0, -1	0, -1, 0	0, 0, 0

- a. Find the pure-strategy Nash equilibrium or equilibria of the game. You can apply the underlying method from the text as follows.

First, find the best responses for A and B , treating each bold box corresponding to C 's choice as a separate game. Then find C 's best responses by comparing corresponding entries in the two boxes (the two entries in the upper-left corners of both, the upper-right corners of both, etc.) and underlining the higher of the two payoffs.

- b. What do you think the outcome would be if players chose cooperatively rather than non-cooperatively?

5.10 Consider the Tragedy of the Commons game from the chapter with two shepherds, A and B , where s_A and s_B denote the number of sheep each grazes on the common pasture. Assume that the benefit per sheep (in terms of mutton and wool) equals

$$300 - s_A - s_B$$

implying that the total benefit from a flock of s_A sheep is

$$s_A(300 - s_A - s_B)$$

and that the marginal benefit of an additional sheep (as one can use calculus to show or can take for granted) is

$$300 - 2s_A - s_B$$

Assume the (total and marginal) cost of grazing sheep is zero since the common can be freely used.

- Compute the flock sizes and shepherds' total benefits in the Nash equilibrium.
- Draw the best-response-function diagram corresponding to your solution.
- Suppose A 's benefit per sheep rises to $330 - s_A - s_B$. Compute the new Nash equilibrium flock sizes. Show the change from the original to the new Nash equilibrium in your best-response-function diagram.



NOT FOR SALE
SOUTH-WESTERN
CENGAGE Learning™



SOUTH-WESTERN
CENGAGE Learning™

NOT FOR SALE

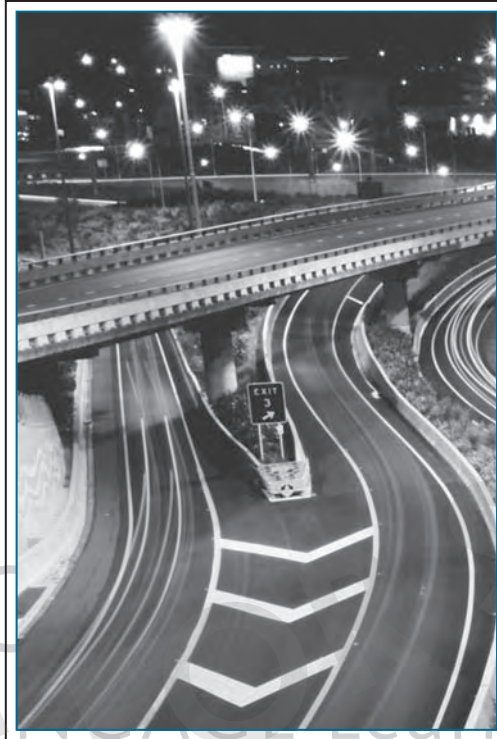

GENERAL EQUILIBRIUM AND WELFARE

In Chapter 9, we looked only at a single competitive market in isolation. We were not concerned with how things that happened in that one market might affect other markets. For many economic issues, this narrowing of focus is helpful—we need only look at what really interests us. For other issues, however, any detailed understanding requires that we look at how many related markets work. For example, if we wished to examine the effects of all federal taxes on the economy, we would need to look not only at a number of different product markets but also at markets for workers and for capital. Econo-

mists have developed both theoretical and empirical (computer) models for this purpose. These are called **general equilibrium models** because they seek to study market equilibrium in many markets at once. The models in Chapter 10, on the other hand, are called **partial equilibrium models** because they are concerned with studying equilibrium in only a single market. In this chapter, we take a very brief look at general equilibrium models. One purpose of this examination is to clarify further the concept of economic efficiency that we introduced in the previous chapter.

General equilibrium model

An economic model of a complete system of markets.

Partial equilibrium model

An economic model of a single market.

A PERFECTLY COMPETITIVE PRICE SYSTEM

The most common type of general equilibrium model assumes that the entire economy works through a series of markets like those we studied in Chapter 9. Not only are all goods allocated through millions of competitive markets but also all inputs have prices that are established through the workings of supply and demand. In all of these many markets, a few basic principles are assumed to hold:

- All individuals and firms take prices as given—they are price takers.
- All individuals maximize utility.
- All firms maximize profits.
- All individuals and firms are fully informed; there are no transactions costs, and there is no uncertainty.

These assumptions should be familiar to you. They are ones we have been making in many other places. One consequence of the assumptions (and a few others) is that it can be shown that when all markets work this way they establish equilibrium prices for all goods.¹ At these prices, quantity supplied equals quantity demanded in every market.

WHY IS GENERAL EQUILIBRIUM NECESSARY?

To see why we need a general model of this type, consider the market for tomatoes that we studied in Chapter 9. Figure 10.1(a) shows equilibrium in this market by the intersection of the demand curve for tomatoes (D) with the supply curve for tomatoes (S). Initially, the price of tomatoes is given by P_1 . Figure 10.1 also shows the markets for three other economic activities that are related to the tomato market: (b) the market for tomato pickers; (c) the market for cucumbers (a substitute for tomatoes in salads); and (d) the market for cucumber pickers. All of these markets are initially in equilibrium. The prices in these various markets will not change unless something happens to shift one of the curves.

Disturbing the Equilibrium

Suppose now that such a change does occur. Imagine a situation where the government announces that tomatoes have been found to cure the common cold so everyone decides to eat more of them. An initial consequence of this discovery is that the demand for tomatoes shifts outward to D' . In our analysis in Chapter 9, this shift would cause the price of tomatoes to rise and that would be, more or less, the end of the story. Now, however, we wish to follow the repercussions of what has happened in the tomato market into the other markets shown in Figure 10.1. A first possible reaction would be in the market for tomato pickers. Because tomato prices

¹Competitive markets can only establish relative, not absolute, prices. That is, these markets can only determine that one apple trades for two oranges, not whether apples and oranges cost \$0.50 and \$0.25 or \$20 and \$10. For this reason, the “price” recorded on the vertical axis of supply and demand curves should always be regarded as a “real” price that shows the price of the good relative to other prices. Absolute (“nominal”) prices in an economy are determined by monetary factors, and we look briefly at these factors at the end of this chapter.

FIGURE 10.1

The Market Cost for Tomatoes and Several Related Markets

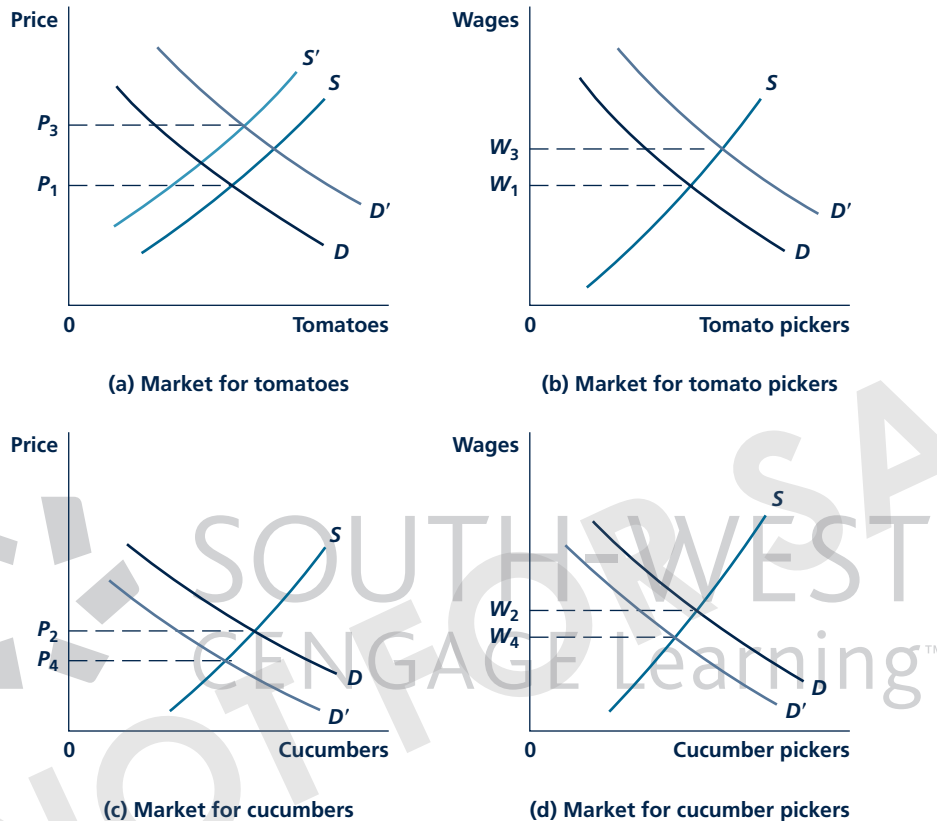

Initially, the market for tomatoes is in equilibrium (at P_1) as are the markets for tomato pickers, cucumbers, and cucumber pickers. An increase in demand for tomatoes disturbs these equilibria. Virtually all the supply and demand curves shift in the process of establishing a new general equilibrium.

have risen, the demand for labor used to harvest tomatoes increases. The demand curve for labor in Figure 10.1(b) shifts to D' . This tends to raise the wages of tomato pickers, which, in turn, raises the costs of tomato growers. The supply curve for tomatoes (which, under perfect competition, reflects only growers' marginal costs) shifts to S' .

What happens to the market for cucumbers? Because people have an increased desire for tomatoes, they may reduce their demands for cucumbers because these tomato substitutes don't cure colds. The demand for cucumbers shifts inward to D' , and cucumber prices fall. That reduces the demand for cucumber workers, and the wage associated with that occupation falls.

Reestablishing Equilibrium

We could continue this story indefinitely. We could ask how the lower price of cucumbers affects the tomato market. Or we could ask whether cucumber pickers, discouraged by their falling wages, might consider picking tomatoes, shifting the supply of labor curve in Figure 10.1(b) outward. To follow this chain of events further or to examine even more markets related to tomatoes would add little to our story. Eventually we would expect all four markets in Figure 10.1 (and all the other markets we have not shown) to reach a new equilibrium, such as that illustrated by the lighter supply and demand curves in the figure. Once all the repercussions have been worked out, the final result would be a rise in tomato prices (to P_3), a rise in the wages of tomato pickers (to w_3), a fall in cucumber prices (to P_4), and a fall in the

wages of cucumber pickers (to w_4). This is what we mean then by a smoothly working system of perfectly competitive markets. Following any disturbance, all the markets can eventually reestablish a new set of equilibrium prices at which quantity demanded is equal to quantity supplied in each market. In Application 10.1: Modeling Excess Burden with a Computer we show why using a model that allows for interconnections among markets provides a more realistic and complete picture of how taxes affect the economy than does the single-market approach we took in Chapter 9.

Micro Quiz 10.1

Why are there two supply curves in Figure 10.1(a)? How does this illustrate “feedback” effects? Why would a partial equilibrium analysis of the effect of an increase in demand for tomatoes from D to D' give the wrong answer?

A SIMPLE GENERAL EQUILIBRIUM MODEL

One way to give the flavor of general equilibrium analysis is to look at a simple supply-demand model of two goods together. Ingeniously, we will call these two goods X and Y . The “supply” conditions for the goods are shown by the production possibility frontier PP' in Figure 10.2. This curve shows the various combinations of X and Y that this economy can produce if its resources are employed efficiently.² The curve also shows the relative opportunity cost of good X in terms of good Y . Therefore, it is similar to a “supply curve” for good X (or good Y).

Figure 10.2 also shows a series of indifference curves representing the preferences of the consumers in this simple economy for the goods X and Y . These indifference curves represent the “demand” conditions in our model. Clearly, in this model, the best use of resources is achieved at point E where production is X^* , Y^* . This point provides the maximum utility that is available in this economy given the limitations imposed by scarce resources (as represented by the production possibility frontier). As in Chapter 9, we define this to be an **economically efficient allocation of resources**. Notice that this notion of efficiency really has two components. First, there is a “supply” component— X^* , Y^* is on the production possibility

Economically efficient allocation of resources

An allocation of resources in which the sum of consumer and producer surplus is maximized. Reflects the best (utility-maximizing) use of scarce resources.

²All of the points on PP' are sometimes referred to as being “technically efficient” in the sense that available inputs are fully employed and are being used in the right combinations by firms. Points inside PP' (such as G) are technically inefficient because it is possible to produce more of both goods. For an analysis of the relationship between input use and technical efficiency, see Problem 10.9.

A P P L I C A T I O N 10.1

Modeling Excess Burden with a Computer

In Chapter 9 we showed that many taxes create “excess burdens” in that they reduce total consumer well-being by more than the amounts collected in tax revenues. A primary shortcoming of our analysis of this issue was that we looked only at a single market—an approach that may significantly understate matters.

Excess Burden in General Equilibrium Models

More precise estimates of the effect of taxation can be obtained from large-scale general equilibrium models. One interesting comparison of excess burden estimates from such models to similar estimates from single-market models found that the simple models may underestimate excess burden by as much as 80 percent.¹ For example, the authors look at a potential five percent tax on energy consumption in the United States and find that the excess burden estimated from a simple model is about \$0.5 billion per year, whereas it is \$2.6 billion per year when studied in a complete model of the economy. The main reason for such large differences is that a single-market analysis fails to consider how an energy tax might affect workers’ labor supply decisions.

Some Other Results

Other examples using general-equilibrium models to evaluate the excess burden of various tax systems are easy to find. For example, early studies of the entire tax system in the United Kingdom found that the distortions introduced by taxes resulted in a deadweight loss of 6 to 9 percent of total GDP.² The tax system imposed particularly heavy costs on British manufacturing industries, perhaps contributing to the country’s relatively poor economic performance prior to the Thatcher reforms.

Another set of examples is provided by papers that look at special tax breaks provided to homeowners in the United States. Probably the two most important such breaks are the

deductibility of mortgage payments for homeowners and the failure to tax the in-kind services people receive from living in their own homes. This special treatment biases peoples’ choices in favor of owning rather than renting and probably causes them to invest more in houses and less in other forms of saving—an effect that was exaggerated by low mortgage rates in 2003–2005. General equilibrium models generally find significant overinvestment in housing, which may impose significant efficiency costs on the U.S. economy.³

Tax Progressivity

Finally, a number of authors have been interested in how the progressive income tax affects welfare in the United States (and elsewhere). The advantage of income tax progressivity is that it may reduce inequality in after-tax incomes, thereby providing some implicit “insurance” to low-income people. The disadvantage of such tax schemes is that the high marginal tax rates required may adversely affect the work and savings behavior of high-income people. An interesting recent paper by Conesa and Krueger uses a computer general equilibrium model to determine whether the degree of progressivity in the U.S. income tax is optimal,⁴ or whether some different scheme would provide similar distributional benefits with less overall excess burden. They find that a flat tax (see Application 1A.2) with a large exemption might increase overall welfare by about 1.7 percent relative to the current system.

POLICY CHALLENGE

Discussions of the wisdom of government projects seldom mention the potential costs involved in the taxes needed to finance them. But most of the studies examined here suggest that such costs can be large. Should the announced “costs” of government projects be increased above their actual resource costs to account for the excess burden of the taxes needed to pay for them?

¹See L. H. Goulder and R. C. Williams III, “The Substantial Bias from Ignoring General Equilibrium Effects in Estimating Excess Burden and a Practical Solution,” *Journal of Political Economy* (August 2003): 898–927.

²Many of the early uses of general equilibrium models to study tax systems are summarized in J. B. Shoven and J. Whalley, “Applied-General Equilibrium Models of Taxation and International Trade,” *Journal of Economic Literature* (September 1985): 1007–1051.

³See Y. Nakagami and A. M. Pereira, “Budgetary and Efficiency Effects of Housing Taxation in the United States,” *Journal of Urban Economics* (September 1996): 68–86.

⁴J. C. Conesa and D. Krueger, “On the Optimal Progressivity of the Income Tax Code,” National Bureau of Economic Research Working Paper 11044 (January 2005).

frontier. Any point inside the frontier would be inefficient because it would provide less utility than can potentially be achieved in this situation. The efficiency of X^* , Y^* also has a “demand” component because, from among all those points on PP' , this allocation of resources provides greatest utility. This reinforces the notion that the ultimate goal of economic activity is to improve the welfare of people. Here, people decide for themselves which allocation is the best.

The efficient allocation shown at point E in Figure 10.2 is characterized by a tangency between the production possibility frontier and consumer's indifference curve. The increasingly steep slope of the frontier shows that X becomes relatively more costly as its production is increased. On the other hand, the slope of an indifference curve shows how people are willing to trade one good for another in consumption (the marginal rate of substitution). That slope flattens as people consume more X because they seek balance in what they have. The tangency in Figure 10.2 therefore shows that one sign of efficiency is that the relative opportunity costs of goods in production should equal the rate at which people are willing to trade these goods for each other. In that way, an efficient allocation ties together technical information about relative costs from the supply side of the market with information about preferences from the demand side. If these slopes were not equal (say at point F) the allocation of resources would be inefficient (utility would be U_1 instead of U_2).

FIGURE 10.2

Efficiency of Output Mix

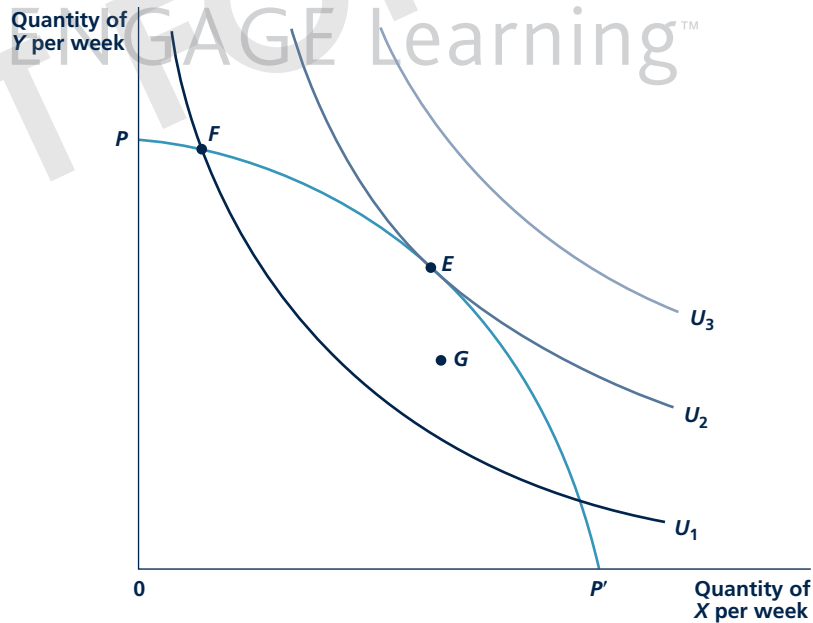

In this economy, the production possibility frontier represents those combinations of X and Y that can be produced. Every point on the frontier is efficient in a technical sense. However, only the output combination at point E is a true utility maximum for the typical person. Only this point represents an economically efficient allocation of resources.

Notice that the description of economic efficiency in Figure 10.2 is based only on the available resources (as shown by the production possibility frontier) and on the preferences of consumers (as shown by the indifference curves). As the definition of “economics” makes clear, the problem faced by any economy is how to make the best use of its available resources. Here, the term “best use” is synonymous with “utility maximizing.” That is, the best use of resources is the one that provides the maximum utility to people. The fact that such an efficient allocation aligns the technical trade-offs that are feasible with the trade-offs people are willing to make (as shown by the tangency at point E in Figure 10.2) also suggests that finding an efficient allocation may have some connection to the correct pricing of goods and resources—a topic to which we now turn.

THE EFFICIENCY OF PERFECT COMPETITION

In this simple model, the “economic problem” is how to achieve this efficient allocation of resources. One of the most important discoveries of modern welfare economics is to show that, under certain conditions, competitive markets can bring about this result. Because of the importance of this conclusion, it is sometimes called the **first theorem of welfare economics**. This “theorem” is simply a generalization of the efficiency result we described in Chapter 9 to many markets. Although a general proof of the theorem requires a lot of mathematics, we can give a glimpse of that proof by seeing how the efficient allocation shown in Figure 10.2 might be achieved through competitive markets.

In Figure 10.3, we have redrawn the production possibility frontier and indifference curves from Figure 10.2. Now assume that goods X and Y are traded in perfectly competitive markets and that the initial prices of the goods are P_X^1 and P_Y^1 , respectively. With these prices, profit-maximizing firms will choose to produce X_1, Y_1 because, from among all the combinations of X and Y on the production possibility frontier, this one provides maximum revenue and profits.³

On the other hand, given the budget constraint represented by line CC , individuals collectively will demand X_1^i, Y_1^i .⁴ Consequently, at this price ratio, there is excess demand for good X (people want to

First theorem of welfare economics

A perfectly competitive price system will bring about an economically efficient allocation of resources.

Micro Quiz 10.2

Suppose that an economy produces only the two goods, left shoes (X) and right shoes (Y). Individuals only want to consume these in combinations for which $X = Y$.

1. Which point (or points) on the production possibility frontier would be economically efficient?
2. Why would a point on the production possibility frontier for which $X = 2Y$ be inefficient?

³The point provides maximum revenue because the prices of X and Y determine the slope of the line CC , which represents total revenue for the firm ($P_X^1 + P_Y^1$), and this line is as far from the origin as possible given that production must take place on PP . But the production possibility frontier assumes that total input usage is the same everywhere on and inside the frontier. Hence, maximization of revenue also amounts to maximization of profits.

⁴It is important to recognize why the budget constraint has this location. Because P_X^1 and P_Y^1 are given, the value of total production is

$$P_X^1 \cdot X_1 + P_Y^1 \cdot Y_1$$

This is the value of total output in the simple economy pictured in the figure. Because of the accounting identity “value of income = value of output,” this is also the total income accruing to people in society. Society’s budget constraint passes through X_1, Y_1 and has a slope of $-P_X^1/P_Y^1$. This is precisely the line labeled CC in the figure.

FIGURE 10.3

How Perfectly Competitive Prices Bring about Efficiency

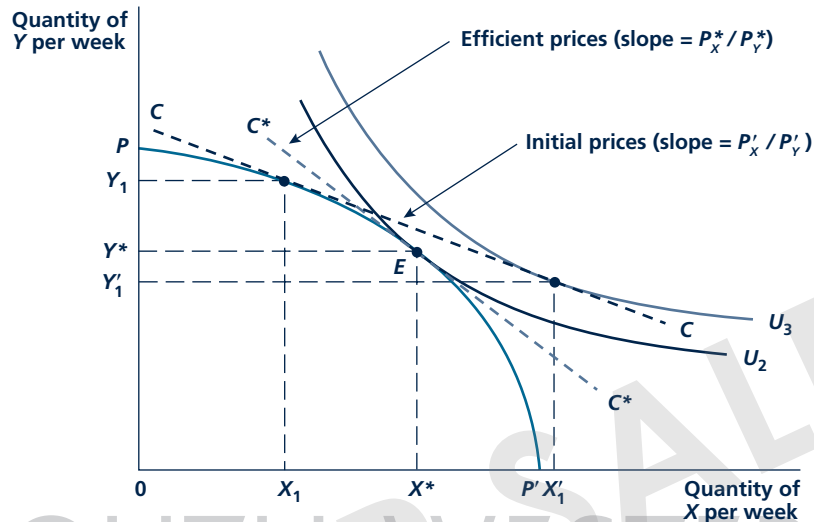

With an arbitrary initial price ratio, firms will produce X_1, Y_1 ; the economy's budget constraint will be given by line CC . With this budget constraint, individuals demand X'_1, Y'_1 , that is, there is an excess demand for good X ($X'_1 - X_1$) and an excess supply of good Y ($Y_1 - Y'_1$). The workings of the market will move these prices toward their equilibrium levels P^*_X, P^*_Y . At those prices, society's budget constraint will be given by the line C^*C^* , and supply and demand will be in equilibrium. The combination X^*, Y^* of goods will be chosen, and this allocation is efficient.

buy more than is being produced), whereas there is an excess supply of good Y . The workings of the marketplace will cause P^*_X to rise and P^*_Y to fall. The price ratio P^*_X/P^*_Y will rise; the price line will move clockwise along the production possibility frontier. That is, firms will increase their production of good X and decrease their production of good Y . Similarly, people will respond to the changing prices by substituting Y for X in their consumption choices. The actions of both firms and individuals simultaneously eliminate the excess demand for X and the excess supply of Y as market prices change.

Equilibrium is reached at X^*, Y^* , with an equilibrium price ratio of P^*_X/P^*_Y . With this price ratio, supply and demand are equilibrated for both good X and good Y . Firms, in maximizing their profits, given P^*_X and P^*_Y , will produce X^* and Y^* . Given the income that this level of production provides to people, they will purchase precisely X^* and Y^* . Not only have markets been

Micro Quiz 10.3

Draw simple supply and demand curve models for determining the prices of X and Y in Figure 10.3. Show the "disequilibrium" points X_1 and X'_1 on your diagram for good X and points Y_1 and Y'_1 on your diagram for good Y . Describe how *both* of these markets reach equilibrium simultaneously.

equilibrated by the operation of the price system, but the resulting equilibrium is also economically efficient. As we showed previously, the equilibrium allocation X^* , Y^* provides the highest level of utility that can be obtained given the existing production possibility frontier. Figure 10.3 provides a simple two-good general equilibrium proof of the first theorem of welfare economics.

Some Numerical Examples

Let's look at a few numerical examples that illustrate the connection between economic efficiency and pricing in a general equilibrium context. In all of these examples, we will assume that there are only two goods (X and Y) and that the production possibility frontier for this economy is a quarter-circle given by the equation:

$$X^2 + Y^2 = 100, \quad X \geq 0, \quad Y \geq 0. \quad (10.1)$$

This production possibility frontier is shown in Figure 10.4. Notice that the maximum amount of X that can be produced is 10 (if $Y = 0$) and that the maximum amount of Y that can be produced (if $X = 0$) is also 10.

Calculating the slope of this production possibility frontier at any point on it is mainly a problem in calculus; hence, we will show it in a footnote.⁵ But the result that the slope is given by the ratio $-X/Y$ will prove useful in working many problems. Now, we must introduce preferences to discover which of the points on the production possibility frontier are economically efficient.

FIGURE 10.4

Hypothetical Efficient Allocations

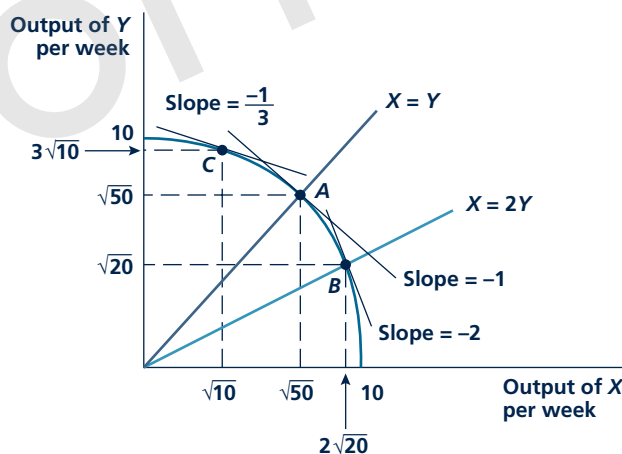

Here, the production possibility frontier is given by $X^2 + Y^2 = 100$. If preferences require $X = Y$, point A will be efficient and $P_X/P_Y = 1$. If preferences require $X = 2Y$, point B will be efficient, $P_X/P_Y = 2$. If preferences require $P_X/P_Y = 1/3$, point C is efficient.

⁵Take the total differential of equation 10.1: $2XdX + 2YdY = 0$ and solve for the slope: $dY/dX = -2X/2Y = -X/Y$.

Fixed Proportions Suppose that people wish to consume these two goods in the fixed ratio $X = Y$ (for example, suppose these are left and right shoes). Then, substituting this requirement into the equation for the production possibility frontier would yield:

$$X^2 + X^2 = 2X^2 = 100 \text{ or } X = Y = \sqrt{50}. \quad (10.2)$$

This efficient allocation is denoted as point *A* in Figure 10.4. The slope of the production possibility frontier at this point would be $-X/Y = -\sqrt{50}/\sqrt{50} = -1$. Hence, with these preferences, the technical trade-off rate between *X* and *Y* is one-for-one; that is, in competitive markets, the goods will have the same price (and relative opportunity costs).

If peoples' preferences were different, the efficient allocation would also be different. For example, if people wish to consume only combinations of the two goods for which $X = 2Y$, then, substituting into Equation 10.1 yields:

$$(2Y)^2 + Y^2 = 5Y^2 = 100, \quad Y = \sqrt{20}, \quad X = 2\sqrt{20}. \quad (10.3)$$

This is shown by point *B* in Figure 10.4. At this point, the slope of the production possibility frontier is $-X/Y = -2\sqrt{20}/\sqrt{20} = -2$. So, the price of good *X* would be twice that of good *Y*; the fact that more *X* is demanded in conjunction with the increasing opportunity cost of producing this good (as shown by the concave shape of the production possibility frontier) account for this result.

Perfect Substitutes When goods are perfect substitutes, individual's marginal rates of substitution between the goods will determine relative prices. This is the only price ratio that can prevail in equilibrium because at any other price ratio, individuals would choose to consume only one of the goods. For example, if people view *X* and *Y* as perfect substitutes for which they are always willing to trade the goods on a one-for-one basis, then the only price ratio that can prevail in equilibrium is 1.0. If good *X* were cheaper than good *Y*, this person would only buy *X*, and if it were more expensive than good *Y*, he or she would only buy *Y*. Therefore, the efficient allocation should be where the slope of the production possibility frontier is -1.0 . Using this fact, we have: Slope = $-X/Y = -1$, so $X = Y$, and equilibrium must again be at point *A* in Figure 10.4. But notice that the reason for being at *A* differs from our reason in the fixed proportions case. In that earlier case, the efficient point was at *A* because people want to consume *X* and *Y* in a one-to-one ratio. In this case, people are willing to consume the two goods in any ratio, but, because the goods are perfect substitutes, the slope of the production possibility frontier must be -1.0 . Finding where this slope occurs determines the efficient allocation in this case.

To illustrate, suppose people viewed *X* and *Y* as perfect substitutes but were always willing to trade 3 units of *X* for 1 unit of *Y*. In this case, the price ratio must be $P_X/P_Y = 1/3$. Setting this equal to the slope of the production possibility frontier yields: Slope = $-X/Y = -1/3$ so $Y = 3X$, and the point on the production possibility frontier can be found by:

$$\begin{aligned} X^2 + (3X)^2 &= 10X^2 = 100 \text{ so} \\ X &= \sqrt{10} \text{ and } Y = 3\sqrt{10}. \end{aligned} \quad (10.4)$$

This allocation is shown by point C in Figure 10.4. Because the relative price of X must be low in equilibrium, relatively little of that good will be produced to avoid incurring unwarranted opportunity costs higher than $1/3$.

Other Preferences Finding the efficient allocation and associated prices with other kinds of preferences will usually be more complicated than these two simple examples. Still, the basic method of finding the correct tangency on the production possibility frontier continues to apply. This tangency not only indicates which of the allocations on the frontier is efficient (because it meets individual preferences), but it also shows the price ratio that must prevail in order to lead both firms and individuals to this allocation.

KEEP *in* MIND

Slopes and Tangencies Determine Efficient Allocations

Efficiency in economics relates to the trade-offs that firms and individuals make. These trade-offs are captured by the slope of the production possibility frontier and by the slopes of individuals' indifference curves. The efficient points cannot be found by dealing with quantities alone. This is a mistake beginning students often make—they try to find solutions without ever looking at trade-off rates (slopes). This approach “worked” in our first example because you just had to find the point of the production possibility frontier where $X = Y$. But, even in that case, it was impossible to calculate relative prices without knowing the slope of the frontier at this point. In more complicated cases, it will be generally impossible even to find an efficient allocation without carefully considering the trade-off rates involved.

Prices, Efficiency, and Laissez-Faire Economics

We have shown that a perfectly competitive price system, by relying on the self-interest of people and of firms and by utilizing the information carried by equilibrium prices, can arrive at an economically efficient allocation of resources. This finding provides “scientific” support for the laissez-faire position taken by many economists. For example, take Adam Smith’s assertion that

The natural effort of every individual to better his own condition, when suffered to exert itself with freedom and security, is so powerful a principle that it is alone, and without any assistance, not only capable of carrying on the society to wealth and prosperity, but of surmounting a hundred impertinent obstructions with which the folly of human laws too often encumbers its operations....⁶

We have seen that this statement has considerable theoretical validity. As Smith noted, it is not the public spirit of the baker that provides bread for people to eat. Rather, bakers (and other producers) operate in their own self-interest in responding to market signals (Smith’s invisible hand). In so doing, their actions are coordinated by the market into an efficient, overall pattern. The market system, at least in this simple model, imposes a very strict logic on how resources are used.

⁶Adam Smith, *The Wealth of Nations* (1776; repr., New York: Random House, 1937), 508. Citations are to the Modern Library edition.

That efficiency theorem raises many important questions about the ability of markets to arrive at these perfectly competitive prices and about whether the theorem should act as a guide for government policy (for example, whether governments should avoid interfering in international markets as suggested by Application 10.2: Gains from Free Trade and the NAFTA and CAFTA Debates).

WHY MARKETS FAIL TO ACHIEVE ECONOMIC EFFICIENCY

Showing that perfect competition is economically efficient depends crucially on all of the assumptions that underlie the competitive model. Several conditions that may prevent markets from generating such an efficient allocation.

Imperfect Competition

Imperfect competition

A market situation in which buyers or sellers have some influence on the prices of goods or services.

Imperfect competition in a broad sense includes all those situations in which economic actors (that is, buyers or sellers) exert some market power in determining price. The essential aspect of all these situations is that marginal revenue is different from market price since the firm is no longer a price taker. Because of this, relative prices no longer accurately reflect marginal costs, and the price system no longer carries the information about costs necessary to ensure efficiency. The deadweight loss from monopoly that we will study in Chapter 11 is a good measure of this inefficiency.

Externalities

Externality

The effect of one party's economic activities on another party that is not taken into account by the price system.

A price system can also fail to allocate resources efficiently when there are cost relationships among firms or between firms and people that are not adequately represented by market prices. Examples of these are numerous. Perhaps the most common is the case of a firm that pollutes the air with industrial smoke and other debris. This is called an **externality**. The firm's activities impose costs on other people, and these costs are not taken directly into account through the normal operation of the price system. The basic problem with externalities is that firms' private costs no longer correctly reflect the social costs of production. In the absence of externalities, the costs a firm incurs accurately measure social costs. The prices of the resources the firm uses represent all the opportunity costs involved in production. When a firm creates externalities, however, there are additional costs—those that arise from the external damage. The fact that pollution from burning coal to produce steel causes diseases and general dirt and grime is as much a cost of production as are the wages paid to the firm's workers. However, the firm responds only to private input costs of steel production in deciding how much steel to produce. It disregards the social costs of its pollution. This results in a gap between market price and (social) marginal cost and therefore leads markets to misallocate resources. In Chapter 16, we look at this issue in some detail.

Public Goods

Public goods

Goods that are both nonexclusive and nonrival.

A third potential failure of the price system to achieve efficiency stems from the existence of certain types of goods called **public goods**. These goods have two

characteristics that make them difficult to produce efficiently through private markets. First, the goods can provide benefits to one more person at zero marginal cost. In this sense the goods are “nonrival,” in that the cost of producing them cannot necessarily be assigned to any specific user. Second, public goods are “nonexclusive”—no person can be excluded from benefiting from them. That is, people gain from the good being available, whether they actually pay for it or not.

To see why public goods pose problems for markets, consider the most important example, national defense. Once a national defense system is in place, one more person can enjoy its protection at zero marginal cost, so this good is nonrival. Similarly, all people in the country benefit from being protected whether they like it or not. It is not possible to exclude people from such benefits, regardless of what they do. Left to private markets, however, it is extremely unlikely that national defense would be produced at efficient levels. Each person would have an incentive to pay nothing voluntarily for national defense, in the hope that others would pay instead. Everyone would have an incentive to be a “free rider,” relying on spending by others (which would never materialize). As a result, resources would then be under-allocated to national defense in a purely market economy. To avoid such misallocations, communities will usually decide to have public goods (other examples are legal systems, traffic control systems, or mosquito control) produced by the government and will finance this production through some form of compulsory taxation. Economic issues posed by this process are also discussed in detail in Chapter 16.

Imperfect Information

Throughout our discussion of the connection between perfect competition and economic efficiency, we have been implicitly assuming that the economic actors involved are fully informed. The most important kind of information they are assumed to have is a knowledge of equilibrium market prices. If for some reason markets are unable to establish these prices or if demanders or suppliers do not know what these prices are, the types of “invisible hand” results we developed may not hold. Consider, for example, the problem that any consumer faces in trying to buy a new television. Not only does he or she have to make some kind of judgment about the quality of various brands (to determine what the available “goods” actually are) but this would-be buyer also faces the problem of finding out what various sellers are charging for a particular set. All of these kinds of problems have been assumed away so far by treating goods as being homogeneous and having a universally known market price. As we will see in Chapter 15, if such assumptions do not hold, the efficiency of perfectly competitive markets is more problematic.

EFFICIENCY AND EQUITY

So far in this chapter we have discussed the concept of economic efficiency and whether an efficient allocation of resources can be achieved through reliance on market forces. We have not mentioned questions of **equity** or fairness in the way goods are distributed among people. In this section, we briefly take up this question. We show not only that it is very difficult to define what an equitable distribution of resources is but also that there is no reason to expect that allocations that result

Equity

The fairness of the distribution of goods or utility.

APPLICATION 10.2

Gains from Free Trade and the NAFTA and CAFTA Debates

Free trade has been controversial for centuries. One of the most influential debates about trade took place following the Napoleonic Wars in Britain during the 1820s and 1830s. The primary focus of the debate concerned how eliminating high tariffs on imported grain would affect the welfare of various groups in society. Many of the same arguments made in the debate over these “Corn Laws” have reappeared nearly two centuries later in modern debates over free-trade policies.

General Equilibrium Theory of Free Trade

A general equilibrium model is needed to study the impact of free trade on various segments of society. One simple version of such a model is shown in Figure 1. The figure shows those combinations of grain (X) and manufactured goods (Y) that can be produced by, say, British factors of production. If the Corn Laws prevented all trade, point E would represent the domestic equilibrium. Britain would produce and consume quantities X_E and Y_E , and these

FIGURE 1 Analysis of the Corn Laws Debate

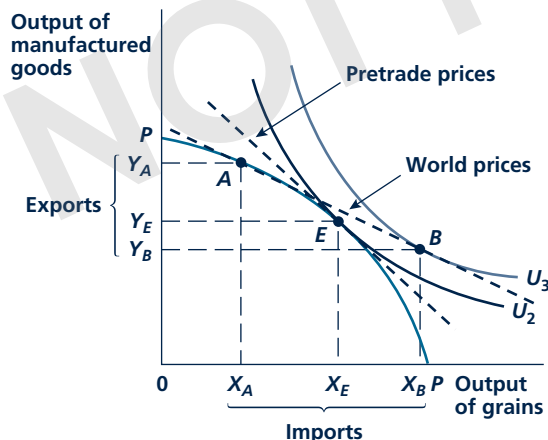

Reduction of tariff barriers on grain would cause production to be reallocated from point E to point A . Consumption would be reallocated from E to B . If grain production were relatively capital intensive, the relative price of capital would fall as a result of these reallocations.

would yield a utility level of U_2 to the typical British person. Removal of the tariffs would reduce the prevailing domestic price ratio to reflect world prices where grain is cheaper. At these world prices, Britain would reduce its production of grain from X_E to X_A and increase its production of manufactured goods from Y_E to Y_A . Trade with the rest of Europe would permit British consumption to move to point B . The country would import grain in amounts $X_B - X_A$ and export manufactured goods $Y_A - Y_B$. The utility of the typical British consumer would rise to U_3 . Hence, adoption of free trade can involve substantial welfare gains.

But trade can also affect the prices of various inputs. Because British production has been reallocated from point E to point A , the demand for inputs used in the manufacturing industry will increase whereas the demand for inputs used to produce grain will fall. In the British case, this was good news for factory workers but bad news for landowners. Not surprisingly, the landowners strenuously fought repeal of the Corn Laws. Ultimately, however, the fact that both workers and typical British consumers gained from trade carried the day, and Britain became a leading proponent of free trade for the remainder of the nineteenth century.

Modern Resistance to Free Trade

Because opening of free trade has the capacity to affect the incomes of various inputs, that policy continues to be politically controversial to this day. In the United States and most Western countries, for example, export industries tend to demand skilled workers and significant amounts of high-tech capital equipment. Imports, on the other hand, tend to be produced by less-skilled workers. Hence, it might be expected that relaxation of trade barriers would result in rising wages for skilled workers but stagnating or falling wages for workers with fewer skills. This can be seen by the positions that unions take in trade debates—unions representing skilled workers (such as machinists, agricultural equipment workers, or workers in the chemical and petroleum industries) tend to support free trade, whereas those representing less-skilled workers (textiles or footwear, for example) tend to oppose it.

A related reason why workers in import-competing industries will oppose free trade initiatives concerns adjustment costs. When production shifts from import to export goods, workers must move out of industries that produce the imported goods. In general, it seems likely that they will eventually be reemployed in other industries, but they may have to learn new skills to get those jobs and the process of doing so may take some time. Many nations offer

“trade-adjustment” policies that seek to mitigate the costs involved in such transitions by offering worker training or extra unemployment benefits. The U.S. Trade Adjustment Assistance (TAA) program, for example, identifies workers for whom international trade was a cause of job loss. If these workers enter a training program (paid for through government vouchers) they may be able to collect unemployment benefits for up to 78 weeks—a full year longer than is provided for under the normal program of unemployment benefits. Workers who need remedial education can collect even more weeks of benefits. In combination with other assistance (such as subsidized health insurance benefits) TAA therefore provides a considerable cushion to workers affected by trade.¹ Whether such assistance can ever fully compensate for the costs individual workers incur from expansion of trade is an open question, however.

The NAFTA Debate

All of these issues were highlighted in the early 1990s debate over the North American Free Trade Agreement. That agreement significantly reduced trade barriers between the United States, Canada, and Mexico. Early computer modeling of the impact of the NAFTA did indeed suggest that the agreement might pose some short-term costs for low-wage workers.² But the models also showed that such costs were significantly outweighed by the gains to other workers and to consumers in all of the countries involved. Indeed, some of the more complicated general equilibrium models suggested that low-wage workers in the United States might not be especially harmed by the agreement because it might improve the operations of the labor markets in which they work.

The generally beneficial outcomes predicted by the general-equilibrium modeling of NAFTA largely seem to have materialized. Indeed, trade among the United States, Canada, and Mexico has generally increased during the past decade to a much greater extent than was predicted by the models, especially in areas where goods had not traditionally been traded.³ The relatively benign effect of this

¹See K. Baicker and M. Rehavi “Policy Watch: Trade Adjustment Assistance” *Journal of Economic Perspectives*, Spring, 2004: 239–255.

²See N. Lustig, B. Bosworth, and R. Lawrence, eds. *North American Free Trade* (Washington, D.C.: The Brookings Institution, 1992).

³T. J. Kehoe, “An Evaluation of the Performance of Applied General Equilibrium Models of the Impact of NAFTA,” Research Department Staff Report 320, Federal Reserve Bank of Minneapolis (August 2003).

expansion of trade on input markets predicted in the models also seems to be supported by the actual data.

Other Free-Trade Agreements

The apparent success of NAFTA spawned suggestions for a number of additional trading pacts. Relatively modest agreements are now in effect between the United States and Australia, Chile, Singapore, Israel, and Jordan. In early 2005, Congress began debating the Central American Free Trade Agreement (CAFTA) that would eventually phase out all tariffs between the United States and Central American countries (including the Dominican Republic). Major beneficiaries of the agreement in the United States are farmers and ranchers (who currently face numerous restrictions on exporting to Central America) and makers of yarn and fabrics (because the agreement will make garment factories in Central America more competitive with those in Asia). But, like its predecessor, CAFTA is controversial in many quarters and was weighted down with special provisions limiting imports of some goods (once again sugar gets special treatment). The agreement also imposed labor and environmental restrictions on some Central American countries, and some politicians tried to tie its passage to the adoption of restrictions on trade with China. Ultimately, CAFTA passed Congress by a few votes in July 2005, but the fight over such a modest portion of U.S. trade suggested future problems. No new trade agreements (including a long-proposed one with Colombia) have been passed since 2005.

TO THINK ABOUT

- Figure 1 shows that there are two sources of the utility gains from free trade: (1) a consumption gain because consumers can consume combinations of goods that lie outside a nation’s production possibility frontier, and (2) a specialization effect because nations can specialize in producing goods with relatively high world prices. How would you show these effects in Figure 1? What would determine whether the effects were large or small?
- Figure 1 shows that a nation will export goods that have a lower relative price domestically than they do in international markets (in this case, good Y). What factors determine such a nation’s “comparative advantage”?

from a competitive price system (or from practically any other method of allocating resources, for that matter) will be equitable.

Defining and Achieving Equity

A primary problem with developing an accepted definition of “fair” or “unfair” allocations of resources is that not everyone agrees as to what the concept means. Some people might call any allocation “fair” providing no one breaks any laws in arriving at it—these people would call only acquisition of goods by theft “unfair.” Others may base their notions of fairness on a dislike for inequality. Only allocations in which people receive about the same levels of utility (assuming these levels could be measured and compared) would be regarded as fair. On a more practical level, some people think the current distribution of income and wealth in the United States is reasonably fair whereas others regard it as drastically unfair. Welfare economists have devised a number of more specific definitions, but these tend to give conflicting conclusions about which resource allocations are or are not equitable. There is simply no agreement on this issue.⁷

Equity and Competitive Markets

Even if everyone agreed on what a fair allocation of resources (and, ultimately, of people’s utility) is, there would still be the question of how such a situation should be achieved. Can we rely on voluntary transactions among people to achieve fairness, or will something more be required? Some introspection may suggest why voluntary solutions will not succeed. If people start out with an unequal distribution of goods, voluntary trading cannot necessarily erase that inequality. Those who are initially favored will not voluntarily agree to make themselves worse off. Similar lessons apply to participation in competitive market transactions. Because these are voluntary, they may not be able to erase initial inequalities, even while promoting efficient outcomes.

Adopting coercive methods to achieve equity (such as taxes) may involve problems too. For example, in several places in this book, we have shown how taxes may affect people’s behavior and result in efficiency losses that arise from this distortion. Using government’s power to transfer income may therefore be a costly activity; achieving equity may involve important losses of efficiency. Making decisions about equity-efficiency trade-offs is a major source of political controversy throughout the world.

THE EDGEWORTH BOX DIAGRAM FOR EXCHANGE

Issues about equity can best be illustrated with a graphic device called the Edgeworth box diagram. In this diagram, a box is used that has dimensions given by the total quantities of two goods available (we’ll call these goods simply X and Y).

⁷For a discussion of some recent thinking on this topic, see Amartya Sen’s 1998 Nobel Prize Speech, reprinted in A. Sen, “The Possibility of Social Choice,” *American Economic Review* (June 1999): 349–378.

The horizontal dimension of the box represents the total quantity of X available, whereas the vertical height of the box is the total quantity of Y . These dimensions are shown in Figure 10.5. The point O_S is considered to be the origin for the first person (call her Smith). Quantities of X are measured along the horizontal axis rightward from O_S ; quantities of Y , along the vertical axis upward from O_S . Any point in the box can be regarded as some allocation of X and Y to Smith. For example, at point E , Smith gets X_S^E and Y_S^E . The useful property of the Edgeworth box is that the quantities received by the second person (say, Jones) are also recorded by point E . Jones simply gets that part of the total quantity that is left over. In fact, we can regard Jones's quantities as being measured from the origin O_J . Point E therefore also corresponds to the quantities X_J^E and Y_J^E for Jones. Notice that the quantities assigned to Smith and Jones in this manner exactly exhaust the total quantities of X and Y available.

Mutually Beneficial Trades

Any point in the Edgeworth box represents an allocation of the available goods between Smith and Jones, and all possible allocations are contained somewhere in the box. To discover which of the allocations offer mutually beneficial trades, we must introduce these people's preferences. In Figure 10.6, Smith's indifference curve map is drawn with origin O_S . Movements in a northeasterly direction represent higher levels of utility to Smith. In the same figure, Jones's indifference curve map is drawn with the corner O_J as an origin. We have taken Jones's indifference curve map, rotated it 180 degrees, and fit it into the northeast corner of the Edgeworth box. Movements in a southwesterly direction represent increases in Jones's utility level.

Using these superimposed indifference curve maps, we can identify the allocations from which some mutually beneficial trades might be made. Any point for which the MRS for Smith is unequal to that for Jones represents such an opportunity. Consider an arbitrary initial allocation such as point E in Figure 10.5. This point lies on the point of intersection of Smith's indifference curve U_S^1 and Jones's indifference curve U_J^3 . Obviously, the marginal rates of substitution (the slopes of the indifference curves) are not equal at E . Any allocation in the oval-shaped area in Figure 10.6 represents a mutually beneficial trade for these two people—they can both move to a higher level of utility by adopting a trade that moves them into this area.

Efficiency in Exchange

When the marginal rates of substitution of Smith and Jones are equal, however, such mutually beneficial trades are not available. The points M_1 , M_2 , M_3 , and M_4 in Figure 10.6 indicate tangencies of these individuals' indifference curves, and

FIGURE 10.5

Edgeworth Box Diagram

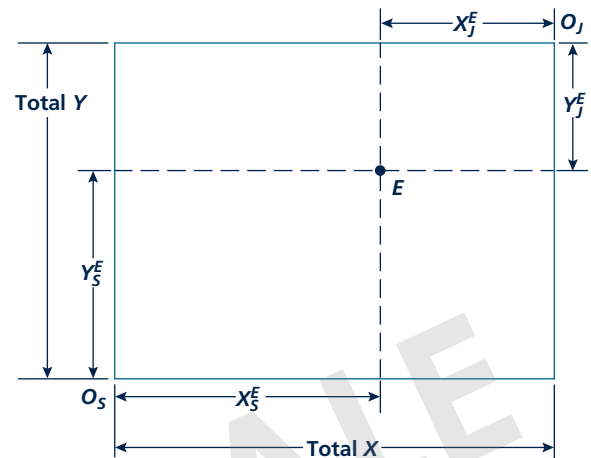

The Edgeworth box diagram permits all possible allocations of two goods (X and Y) to be visualized. If we consider the corner O_S to be Smith's "origin" and O_J to be Jones's, then the allocation represented by point E would have Smith getting X_S^E and Y_S^E , and Jones would receive what is left over (X_J^E , Y_J^E). One purpose of this diagram is to discover which of the possible locations within the box can be reached through voluntary exchange.

FIGURE 10.6

Edgeworth Box Diagram of Pareto Efficiency in Exchange

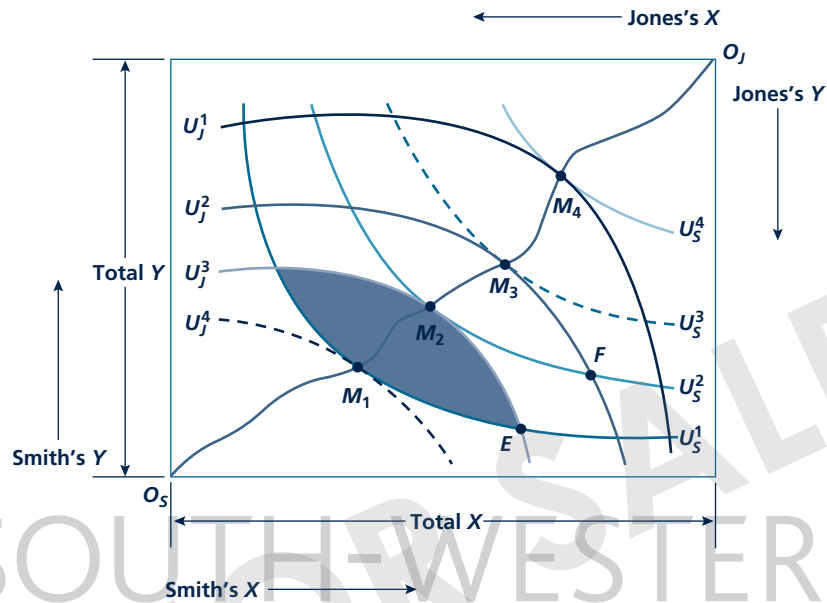

The points on the curve O_S, O_3 are efficient in the sense that at these allocations Smith cannot be made better off without making Jones worse off, and vice versa. An allocation such as E , on the other hand, is inefficient because both Smith and Jones can be made better off by choosing to move into the blue area. Notice that along O_S, O_3 the MRS for Smith is equal to that for Jones. The line O_S, O_3 is called the *contract curve*.

Pareto efficient allocation

An allocation of available resources in which no mutually beneficial trading opportunities are unexploited. That is, an allocation in which no one person can be made better off without someone else being made worse off.

Contract curve

The set of efficient allocations of the existing goods in an exchange situation. Points off that curve are necessarily inefficient, since individuals can be made unambiguously better off by moving to the curve.

movement away from such points must make at least one of the people worse off. A move from M_2 to E , for example, reduces Smith's utility from U_S^2 to U_S^1 , even though Jones is made no worse off by the move. Alternatively, a move from M_2 to F makes Jones worse off but keeps the Smith utility level constant. In general, then, these points of tangency do not offer the promise of additional mutually beneficial trading. Such points are called **Pareto efficient allocations** after the Italian scientist Vilfredo Pareto (1878–1923), who pioneered in the development of the formal theory of exchange. Notice that the Pareto definition of efficiency does not require any interpersonal comparisons of utility; we never have to compare Jones's gains to Smith's losses or vice versa. Rather, individuals decide for themselves whether particular trades improve utility. For efficient allocations, there are no such additional trades to which both parties would agree.

Contract Curve

The set of all the efficient allocations in an Edgeworth box diagram is called the **contract curve**. In Figure 10.6, this set of points is represented by the line running

from O_S to O_J and includes the tangencies M_1 , M_2 , M_3 , and M_4 (and many other such tangencies). Points off the contract curve (such as E or F) are inefficient, and mutually beneficial trades are possible. But, as its name implies, moving onto the contract curve exhausts all such mutually beneficial trading opportunities. A move along the contract curve (say, from M_1 to M_2) does not represent a mutually beneficial trade because there will always be a winner (Smith) and a loser (Jones).

Efficiency and Equity

The Edgeworth box diagram not only allows us to show Pareto efficiency, but also illustrates the problematic relationship between efficiency and equity. Suppose, for example, that everyone agreed that the only fair allocation is one of equal utilities. Perhaps everyone remembers his or her childhood experiences in dividing up a cake or candy bar where equal shares seemed to be the only reasonable solution. This desired allocation might be represented by point E in the Edgeworth exchange box in Figure 10.7. On the other hand, suppose Smith and Jones start out at point A —at which Smith is in a fairly favorable situation. As we described previously, any allocation between M_2 and M_3 is preferable to point A because both people would be better off by voluntarily making such a move. In this case, however, the point of equal utility (E) does not fall in this range. Smith would not voluntarily agree to move to point E since that would make her worse off than at point A . Smith would prefer to refrain from any trading rather than accept the “fair” allocation E . In the language of welfare economics, the **initial endowments** (that is, the starting place for trading) of Smith and Jones are so unbalanced that voluntary agreements will not result in the desired equal allocation of utilities. If point E is to be achieved, some coercion (such as taxation) must be used to get Smith to accept it. The idea that redistributive taxes might be used together with competitive markets to yield allocations of resources that are both efficient and equitable has proven to be a tantalizing prospect for economists, as Application 10.3: The Second Theorem of Welfare Economics illustrates.

Equity and Efficiency with Production

Examining the relationship between equity and efficiency is more complex in a model in which production occurs. In our discussion so far, the size of the Edgeworth Box has been fixed, and we have only looked at how a given supply of two goods can be allocated between two people. After we allow for production, the size of the Edgeworth Box is no longer given but will depend on how much is actually produced in the economy. Of course, we can still study the utility that people get from various potential ways in which this production might be distributed. But now looking at the effects of redistribution of initial endowments becomes more complicated because such redistribution may actually affect how much is produced. For

Micro Quiz 10.4

What would the contract curve look like in the following situations:

1. Smith likes only good X and Jones likes only good Y .
2. Smith and Jones both view X and Y as perfect complements.
3. Smith and Jones are both always willing to substitute one unit of X for one unit of Y and remain equally well-off.

Initial endowments

The initial holdings of goods from which trading begins.

FIGURE 10.7

Voluntary Transactions May Not Result in Equitable Allocations

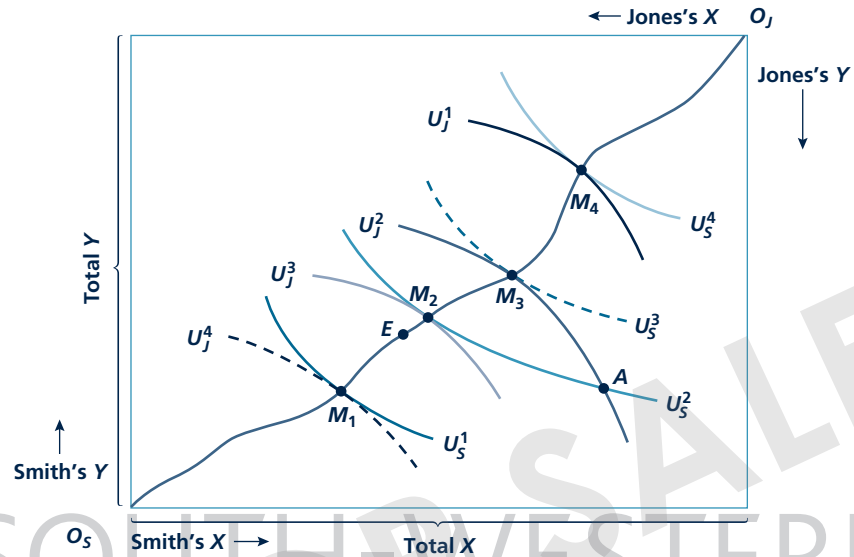

This Edgeworth box diagram for exchange is taken from Figure 10.5. Point E represents a "fair" sharing of the available goods (assuming that can be defined). If individuals' initial endowments are at point A, voluntary transactions cannot be relied on to reach point E since such an allocation makes Smith worse off than at A.

example, if we were considering a plan that would redistribute income from a person with an "initial endowment" of skills to a person with few skills, we would have to consider whether such a plan would affect the high-skilled person's willingness to work. We should also think about whether receipt of income by a person with few skills might also affect this person's behavior. Although the size of such effects is largely an empirical question, it seems likely that such attempts at redistribution would have some (probably negative) effect on production. On a conceptual level then it is unclear whether such redistribution would actually raise the utility of the low-skilled person—production could decrease by enough that both people could be worse off (for an example, see Problem 10.10). Even if such a large effect would appear to be unlikely, it is still important to know what the effects of redistribution policy on production are so that potential tradeoffs between equity and efficiency can be better understood.

MONEY IN GENERAL EQUILIBRIUM MODELS

Thus far in this chapter, we have shown how competitive markets can establish a set of relative prices at which all markets are in equilibrium simultaneously. At several

A P P L I C A T I O N 10.3

The Second Theorem of Welfare Economics

Zealous students of microeconomics will be happy to know that there is, in fact, a “second” theorem of welfare economics that accompanies the more popular first “invisible hand” theorem. This second theorem focuses on equity and shows how competitive markets might be used to achieve that goal. Specifically, the theorem states that any desired allocation of utility among the members of society can be achieved through the operations of competitive markets, *providing* initial endowments are set appropriately. Suppose, for example, that equity dictated that the distribution of utility between Smith and Jones in Figure 10.6 must lie between M_2 and M_3 on the contract curve. The second theorem states that this can be achieved by adjusting initial endowments to point F and then allowing competitive trading between these two people. How this state of affairs might be achieved in the real world is the subject of this application.

Lump-Sum Redistribution

Sometimes the second theorem of welfare economics is paraphrased as “social policy should pursue efficiency (competitive pricing), thereby making the ‘pie’ as big as possible—any resulting undesirable inequalities can be patched up with lump-sum taxes and transfers.” It is this vision that provides the impetus to the adherents of many “free-market” policies. But the view is probably too simplistic for at least two reasons. First, most real-world tax and transfer schemes depart significantly from the lump-sum ideal. That is, virtually all such schemes distort people’s behavior and therefore cause welfare losses of their own. Second, this approach to achieving equity focuses on patching things up after competitive markets have reached equilibrium, but it is unclear whether any political system would in fact adopt such policies. Still, the lump-sum vision is an attractive one because efficiency gains from competitive markets offer opportunities for Pareto improvements, from which everyone can be made better off. The approach has been widely used in applied economics, especially in the field of law and economics, to evaluate various policy options.¹ For example, in the theory of contracts, a lawyer might argue that all contracts should be kept, regardless of unforeseen factors that may have occurred. Economists, on the other hand, have asked whether breaching some types of contracts

¹A good introductory discussion is in R. Posner, *Economic Analysis of Law*, 6th ed. (New York: Aspen Publishers, 2003) chaps. 1 and 2.

might be efficient, creating added utility that could be shared by all parties.

Education and Initial Endowments

Another approach to finding desirable equity-efficiency trade-offs focuses specifically on using general-equilibrium models to study the relative merits of various ways of altering initial endowments. Because many people believe that education may be the best route to achieving a more equitable distribution of income, considerable attention has been devoted to looking at the potential effects of large educational subsidies. In one recent study, for example, the authors use a simple general-equilibrium model to study the equity-efficiency trade-offs that arise through the use of subsidies for higher education.² They then compare these to what might be obtained through taxes and transfers or through a general program of wage subsidies for low-productivity workers. A key element of their model is that people have differing abilities that affect both their chances for success in school (i.e., graduation) and their future wages. Greater subsidies for higher education help to equalize wages but also involve some deadweight losses because they lure people into higher education that is not a good match for their ability. Perhaps surprisingly, the authors conclude that education may not be an efficient way to alter initial endowments. They find that wage subsidies dominate both education and tax/transfer schemes in that any given level of government spending provides more final utility.

POLICY CHALLENGE

Education or training programs are usually conceived as being better than “welfare” as a way of improving the situation of low income people because such programs expand production, whereas welfare programs may reduce it. But the evidence of whether education or training programs really add significantly to peoples’ earning power is mixed, at best. Can education programs be expanded enough to achieve desired distributional goals? Or will it always be necessary to fall back on some forms of (production-reducing) tax and transfer programs?

²E. A. Hanushek, C. K. Y. Leung, and K. Yilmaz, “Redistribution Through Education and Other Transfer Mechanisms,” *Journal of Monetary Economics* (November 2003): 1719–1750.

places we stressed that competitive market forces determine only relative, not absolute, prices and that to examine how the absolute price level is determined we must introduce money into our models. Although a complete examination of this topic is more properly studied as part of macroeconomics, here we briefly explore some questions of the role of money in a competitive economy that relate directly to microeconomics.

Nature and Function of Money

Money serves two primary functions in any economy: (1) it facilitates transactions by providing an accepted medium of exchange, and (2) it acts as a store of value so that economic actors can better allocate their spending decisions over time. Any commodity can serve as “money” provided it is generally accepted for exchange purposes and is durable from period to period. Today most economies tend to use government-created (fiat) money because the costs associated with its production (e.g., printing pieces of paper with portraits of past or present rulers or keeping records on magnetic tape) are very low. In earlier times, however, commodity money was common, with the particular good chosen ranging from the familiar (gold and silver) to the obscure and even bizarre (sharks’ teeth or, on the island of Yap, large stone wheels). Societies probably choose the particular form that their money will take as a result of a wide variety of economic, historical, and political forces.

Money as the Accounting Standard

One of the most important functions money usually plays is to act as an accounting standard. All prices can be quoted in terms of this standard. In general, relative prices will be unaffected by which good (or possibly a basket of goods) is chosen as the accounting standard. For example, if one apple (good 1) exchanges for two plums (good 2):

$$\frac{P_1}{P_2} = \frac{2}{1} \quad (10.5)$$

and it makes little difference how those prices are quoted. If, for example, a society chooses clams as its monetary unit of account, an apple might exchange for four clams and a plum for two clams. If we denote clam prices of apples and plums by P'_1 and P'_2 , respectively, we have

$$\frac{P_1}{P_2} = \frac{4}{2} = \frac{2}{1} = \frac{P'_1}{P'_2} \quad (10.6)$$

We could change from counting in clams to counting in sharks’ teeth by knowing that 10 sharks’ teeth exchange for 1 clam. The price of our goods in sharks’ teeth would be

$$P''_1 = 4 \cdot 10 = 40 \quad (10.7)$$

and

$$P''_2 = 2 \cdot 10 = 20$$

One apple (which costs 40 teeth) would still exchange for 2 plums that cost 20 teeth each.

Of course, using clams or sharks' teeth is not very common. Instead, societies usually adopt paper money as their accounting standard. An apple might exchange for half a piece of paper picturing George Washington (i.e., \$0.50) and a plum for one-fourth of such a piece of paper (\$0.25). Thus, with this monetary standard, the relative price remains two for one. Choice of an accounting standard does not, however, necessarily dictate any particular absolute price level. An apple might exchange for four clams or four hundred, but, as long as a plum exchanges for half as many clams, relative prices will be unaffected by the absolute level that prevails. Absolute price levels are obviously important, however, especially to people who wish to use money as a store of value. A person with a large investment in clams obviously cares about how many apples he or she can buy with those clams. Although a complete theoretical treatment of the price level issue is beyond the scope of this book, we do offer some brief comments here.

Commodity Money

In an economy where money is produced in a way similar to any other good (gold is mined, clams are dug, or sharks are caught), the relative price of money is determined like any other relative price—by the forces of demand and supply. Economic forces that affect either the demand or supply of money will also affect these relative prices. For example, Spanish importation of gold from the New World during the fifteenth and sixteenth centuries greatly expanded gold supplies and caused the relative price of gold to fall. That is, the prices of all other goods rose relative to that of gold—there was general inflation in the prices of practically everything in terms of gold. Similar effects would arise from changes in any factor that affected the equilibrium price for the good chosen as money. Application 10.4: Commodity Money looks at some current debates about adopting a gold or other commodity standard.

Fiat Money and the Monetary Veil

For the case of fiat money produced by the government, the analysis can be extended a bit. In this situation, the government is the sole supplier of money and can generally choose how much it wishes to produce. What effects will this level of money production have on the real economy? In general, the situation would seem to be identical to that for commodity money. A change in the money supply will disturb the general equilibrium of all relative prices, and, although it seems likely that an expansion in supply will lower the relative price of money (that is, result in an inflation in the money prices of other goods), any more precise

Micro Quiz 10.5

Sometimes economists are not very careful when they draw supply and demand curves to state clearly whether the price on the vertical axis is a relative (real) price or a nominal price. How would a pure inflation (in which all prices rise together) affect:

1. A supply and demand curve diagram that has relative price on the vertical axis?
2. A supply and demand curve diagram that has nominal price on the vertical axis?

A P P L I C A T I O N 10.4

Commodity Money

Throughout history both commodity and fiat money have been widely used. Today we are more accustomed to fiat money—money that is produced by the government at a cost much lower than its exchange value. The ability to control the supply of such money gives governments substantial power to control the general price level and many other macroeconomic variables. In contrast, the use of a particular commodity as money tends to arise by historical accident. Once a social consensus is reached that a certain good will serve as a medium of exchange, the amount of such money in circulation will be determined by the usual laws of supply and demand. Some economists believe this is a desirable feature of using commodity money because it severely limits what governments can do in terms of monetary policy. Regardless of where one comes down on this issue, examining some experiences with commodity money can provide insights about how the monetary and real sectors of any economy are related.

The Gold Standard

Gold has been used as money for thousands of years. In the nineteenth century, this use was formalized under the “gold standard.” The process of establishing the standard started in 1821 with the British decision to make the pound freely tradable for gold at a fixed price. Germany and the United States quickly followed the British lead, and by the 1870s most of the world’s major economies tied the values of their currencies to gold. This implicitly established an international system of fixed exchange rates. It also limited the power of governments to create fiat money because of the need to maintain a fixed price of their currencies in terms of gold.

Two features of economic life under the gold standard are worth noting. First, because economic output tended to expand more rapidly than the supply of gold during much of the nineteenth century, this was generally a period of falling prices. That is, the price of gold (and currencies tied to gold) increased relative to the price of other goods. Second, any periods of general inflation tended to be associated with new gold discoveries. This was especially true in the United States following gold discoveries in 1848 (in California) and in 1898 (in the Yukon).

Bimetallism

Gold and silver were both used as commodity money in the early history of the United States. The government set the

official exchange ratio between the two metals, but that ratio did not always reflect true relative scarcities. Usually gold was defined to have an exchange value higher than its true market value, so gold was used for most monetary transactions. But that meant that money was tight because the gold supply was growing only slowly. William Jennings Bryan’s famous “cross of gold” speech in 1896 was essentially a plea to raise the exchange value of silver so that the overall money supply could grow more rapidly. Much of the debate about bimetallism is also reflected in the Frank Baum story *The Wizard of Oz*. For example, the Wicked Witch of the East represents Eastern bankers who wished to maintain a gold-only standard.¹ More generally, experiences with bimetallism show how difficult it is to maintain fixed money prices for two different commodity moneys when the underlying values of the commodities are subject to the laws of supply and demand.

Cigarettes as Money

An interesting example of commodity money arising in strained circumstances is provided by R. A. Radford’s famous account of his experiences in a POW camp during World War II.² Radford shows that prisoners soon settled on cigarettes as a commodity “money.” It was mainly British or French cigarettes that were used as money, because American cigarettes were generally regarded as better for smoking. Arrival of Red Cross packages with fresh cigarette supplies generally led to an overall inflation in the cigarette prices of other goods.

TO THINK ABOUT

1. Suppose you could dictate which commodity would be used as a monetary standard, what criteria would you use in selecting the good to be used?
2. Radford’s observation about American cigarettes is an example of Gresham’s Law—that “bad” money drives out “good” money. Can you think of other historical examples of this phenomenon?

¹For a complete discussion, see H. Rockoff, “The Wizard of Oz as a Monetary Allegory,” *Journal of Political Economy* (August 1990): 739–760.

²R. A. Radford, “The Economic Organization of a POW Camp,” *Economica* (November 1945): 189–201.

prediction would seem to depend on the results of a detailed general equilibrium model of supply and demand in many markets.

Beginning with David Hume, however, classical economists argued that fiat money differs from other economic goods and should be regarded as being outside the real economic system of demand, supply, and relative price determination. In this view, the economy can be dichotomized into a real sector in which relative prices are determined and a monetary sector where the absolute price level (that is, the value of fiat money) is set. Money, therefore, acts only as a “veil” for real economic activity; the quantity of money available has no effect on the real sector.⁸ Whether this is true is an important unresolved issue in macroeconomics.

SUMMARY

We began this chapter with a description of a general equilibrium model of a perfectly competitive price system. In that model, relative prices are determined by the forces of supply and demand, and everyone takes these prices as given in their economic decisions. We then arrive at the following conclusions about such a method for allocating resources:

- Profit-maximizing firms will use resources efficiently and will therefore operate on the production possibility frontier.
- Profit-maximizing firms will also produce an economically efficient mix of outputs. The workings of supply and demand will ensure that the technical rate at which one good can be transformed into another in production (the rate of product transformation, RPT) is equal to the rate at which people are willing to trade one good for another (the MRS). Adam Smith’s invisible hand brings considerable coordination into seemingly chaotic market transactions.
- Factors that interfere with the ability of prices to reflect true marginal costs under perfect competition will prevent an economically efficient allocation of resources. Such factors include imperfect competition, externalities, and public goods. Imperfect information about market prices may also interfere with the efficiency of perfect competition.
- Under perfect competition, there are no forces to ensure that voluntary transactions will result in equitable final allocations. Achieving equity may require some coercion to transfer initial endowments. Such interventions may involve costs in terms of economic efficiency.
- A perfectly competitive price system establishes only relative prices. Introduction of money into the competitive model is needed to show how nominal prices are determined. In some cases the amount of money (and the absolute price level) will have no effect on the relative prices established in competitive markets.

⁸This leads directly to the quantity theory of the demand for money, first suggested by Hume:

$$D_M = \frac{1}{V} \cdot P \cdot Q$$

where D_M is the demand for money, V is the velocity of monetary circulation (the number of times a dollar is used each year), P is the overall price level, and Q is a measure of the quantity of transactions (often approximated by real GDP). If V is fixed and Q is determined by real forces of supply and demand, a doubling of the supply of money will result in a doubling of the equilibrium price level.

REVIEW QUESTIONS

1. “An increase in demand will raise a good’s price and a fall in demand will lower it. That is all you need to know – general equilibrium analysis is largely unnecessary.” Do you agree? How would you use Figure 10.3 to show how changes in demand affect price? Would using this figure tell you more than would using a simple supply-demand diagram?
2. How does the approach to economic efficiency taken in Chapter 9 relate to the one taken here? How is the possible inefficiency in Figure 9.1 related to that in Figure 10.2?
3. Why are allocations on the production possibility frontier technically efficient? What is technically inefficient about allocations inside the frontier? Do inefficient allocations necessarily involve any unemployment of factors of production? In the model introduced in this chapter, would unemployment be technically inefficient?
4. In Chapter 9 we showed that the imposition of a tax involves an “excess burden”. How would you show a similar result with a general equilibrium diagram such as Figure 10.3? (Note: with the general equilibrium diagram you must be more specific about how tax revenue is used)
5. Suppose two countries had differing production possibility frontiers and were currently producing at points with differing slopes (that is, differing relative opportunity costs). If there were no transportation or other charges associated with international transactions, how might world output be increased by having these firms alter their production plans? Develop a simple numerical example of these gains for the case where both countries have linear production possibility frontiers (with different slopes). Interpret this result in terms of the concept of “comparative advantage” from the theory of international trade.
6. Use a simple two-good model of resource allocation (such as that in Figure 10.2) to explain the difference between technical efficiency and economic (or allocative) efficiency. Would you agree with the statement that “economic efficiency requires technical efficiency, but many technically efficient allocations are not economically efficient”? Explain your reasoning with a graph.
7. In Chapter 9 we showed how a shift in demand could be analyzed using a model of a single market. How would you illustrate an increase in the demand for good X in the general equilibrium model pictured in Figure 10.3? Why would such a shift in preferences cause the relative price of X to rise? What would happen to the market for good Y in this case? Should your discussion here be thought of as “short-run” or “long-run” analysis?
8. Relative prices convey information about both production possibilities and people’s preferences. What exactly is that information and how does its availability help attain an efficient allocation of resources? In what ways does the presence of monopoly or externalities result in price information being “inaccurate”?
9. Suppose that the competitive equilibrium shown in Figure 10.3 were regarded as “unfair” because the relative price of X (an important necessity) is “too high.” What would be the result of passing a law requiring that P_X/P_Y be lower?
10. In most of the theoretical examples in this book, prices have been quoted in dollars or cents. Is this choice of currency crucial? Would most examples be the same if prices had been stated in pounds, marks, or yen? Or, would it have mattered if the dollars used were “1900 dollars” or “2000 dollars”? How would you change the endless hamburger–soft drink examples, say, to phrase them in some other currency? Would such changes result in any fundamental differences? Or, do most of the examples in this book seem to display the classical dichotomy between real and nominal magnitudes?

PROBLEMS

10.1 Suppose the production possibility frontier for cheeseburgers (C) and milkshakes (M) is given by

$$C + 2M = 600$$

- a. Graph this function.

- b. Assuming that people prefer to eat two cheeseburgers with every milkshake, how much of each product will be produced? Indicate this point on your graph.

- c. Given that this fast food economy is operating efficiently, what price ratio (P_C/P_M) must prevail?

10.2 Consider an economy with just one technique available for the production of each good, food and cloth:

GOOD	FOOD	CLOTH
Labor per unit output	1	1
Land per unit output	2	1

- a. Supposing land is unlimited but labor equals 100, write and sketch the production possibility frontier.
- b. Supposing labor is unlimited but land equals 150, write and sketch the production possibility frontier.
- c. Supposing labor equals 100 and land equals 150, write and sketch the production possibility frontier. (Hint: What are the intercepts of the production possibility frontier? When is land fully employed? Labor? Both?)
- d. Explain why the production possibility frontier of part c is concave.
- e. Sketch the relative price of food as a function of its output in part c.
- f. If consumers insist on trading four units of food for five units of cloth, what is the relative price of food? Why?
- g. Explain why production is exactly the same at a price ratio of $P_F/P_C = 1.1$ as at $P_F/P_C = 1.9$.
- h. Suppose that capital is also required for producing food and cloth and that capital requirements per unit of food are 0.8 and per unit of cloth 0.9. There are 100 units of capital available. What is the production possibility curve in this case? Answer part e for this case.

10.3 Suppose the production possibility frontier for guns (X) and butter (Y) is given by

$$X^2 + 2Y^2 = 900$$

- a. Graph this frontier.
- b. If individuals always prefer consumption bundles in which $Y = 2X$, how much X and Y will be produced?
- c. At the point described in part b, what will be the slope of the production possibility frontier, and what price ratio will cause production to take place at that point? (Hint: By using the approach in the numerical examples in this

chapter, show that the slope of this production possibility frontier is $-X/2Y$.)

- d. Show your solution on the figure from part a.

10.4 Robinson Crusoe obtains utility from the quantity of fish he consumes in one day (F), the quantity of coconuts he consumes that day (C), and the hours of leisure time he has during the day (H) according to the utility function:

$$Utility = F^{1/4} C^{1/4} H^{1/2}$$

Robinson's production of fish is given by

$$F = \sqrt{L_F}$$

(where L_F is the hours he spends fishing), and his production of coconuts is determined by

$$C = \sqrt{L_C}$$

(where L_C is the time he spends picking coconuts). Assuming that Robinson decides to work an eight-hour day (that is, $H = 16$), graph his production possibility curve for fish and coconuts. Show his optimal choices of those goods.

10.5 Suppose two individuals (Smith and Jones) each have 10 hours of labor to devote to producing either ice cream (X) or chicken soup (Y). Smith's demand for X and Y is given by

$$X_S = \frac{0.3I_S}{P_X}$$

$$Y_S = \frac{0.7I_S}{P_Y}$$

whereas Jones's demands are given by

$$X_J = \frac{0.5I_J}{P_X}$$

$$Y_J = \frac{0.5I_J}{P_Y}$$

where I_S and I_J represent Smith's and Jones's incomes, respectively (which come only from working).

The individuals do not care whether they produce X or Y and the production function for each good is given by

$$X = 2L$$

$$Y = 3L$$

where L is the total labor devoted to production of each good. Using this information, answer the following:

- What must the price ratio, P_X/P_Y be?
- Given this price ratio, how much X and Y will Smith and Jones demand? (Hint: Set the wage equal to 1 here so that each person's income is 10.)
- How should labor be allocated between X and Y to satisfy the demand calculated in part b?

10.6 In the country of Ruritania there are two regions, A and B . Two goods (X and Y) are produced in both regions. Production functions for region A are given by

$$X_A = \sqrt{L_X}$$

$$Y_A = \sqrt{L_Y}$$

L_X and L_Y are the quantity of labor devoted to X and Y production, respectively. Total labor available in region A is 100 units. That is,

$$L_X + L_Y = 100$$

Using a similar notation for region B , production functions are given by

$$X_B = 1/2\sqrt{L_X}$$

$$Y_B = 1/2\sqrt{L_Y}$$

There are also 100 units of labor available in region B :

$$L_X + L_Y = 100$$

- Calculate the production possibility curves for regions A and B .
- What condition must hold if production in Ruritania is to be allocated efficiently between regions A and B (assuming that labor cannot move from one region to the other)?
- Calculate the production possibility curve for Ruritania (again assuming that labor is immobile between regions). How much total Y can Ruritania produce if total X output is 12? (Hint: A graphic analysis may be of some help here.)
- Without making any explicit calculations, explain how you might develop a production possibility frontier for this whole country.

10.7 There are 200 pounds of food on an island that must be allocated between 2 marooned sailors. The utility function of the first sailor is given by

$$\text{Utility} = \sqrt{F_1}$$

where F_1 is the quantity of food consumed by the first sailor. For the second sailor, utility (as a function of food consumption) is given by

$$\text{Utility} = 1/2\sqrt{F_2}$$

- If the food is allocated equally between the sailors, how much utility will each receive?
- How should food be allocated between the sailors to ensure equality of utility?
- Suppose that the second sailor requires a utility level of at least 5 to remain alive. How should food be allocated so as to maximize the sum of utilities subject to the restraint that the second sailor receives that minimum level of utility?
- What other criteria might you use to allocate the available food between the sailors?

10.8 Return to Problem 10.7 and now assume that Smith and Jones conduct their exchanges in paper money. The total supply of such money is \$60 and each individual wishes to hold a stock of money equal to $1/4$ of the value of transactions made per period.

- What will the money wage rate be in this model? What will the nominal prices of X and Y be?
- Suppose the money supply increases to \$90, how will your answers to part a change? Does this economy exhibit the classical dichotomy between its real and monetary sectors?

10.9 The Edgeworth box diagram can also be used to show how a production possibility frontier is constructed for an economy as a whole. Suppose there are only two goods that might be produced (X and Y), each using two inputs, capital (K) and labor (L). In order to construct the X - Y production possibility frontier, we must look for efficient allocations of the total capital and labor available.

- Draw an Edgeworth box with dimensions given by the total quantities of capital and labor available (see Figure 10.4).
- Consider the lower-left corner of the box to be the origin for the isoquant map for good X . Draw a few of the X isoquants.
- Now consider the upper-right corner of the box to be the origin for the isoquant map for good Y . Draw a few Y isoquants (as in Figure 10.5) in the Edgeworth box.
- What are the efficient points in the box you have drawn? What condition must hold for a given allocation of K and L to be efficient?

- e. The production possibility frontier for X and Y consists of all the efficient allocations in the Edgeworth box. Explain why this is so. Also explain why inefficient points in the box would be *inside* the production possibility frontier.
- f. Use the connection between your box diagram and the production possibility frontier to discuss what the frontier would look like in the following cases:
- Production of good X uses only labor, production of good Y uses only labor.
 - Both X and Y are produced using K and L in the same fixed proportions as the inputs are available in the economy and both exhibit constant returns to scale.
 - Both X and Y have the same production function and both exhibit constant returns to scale.
 - Both X and Y are produced using the same production function and both exhibit increasing returns to scale.
- 10.10** Smith and Jones are stranded on a desert island. Each has in her possession some slices of ham (H) and cheese (C). Smith prefers to consume ham and cheese in the fixed proportions of 2 slices of cheese to each slice of ham. Her utility function is given by $U_S = \text{Min}(10H, 5C)$. Jones, on the other hand, regards ham and cheese as perfect substitutes—she is always willing to trade 3 slices of ham for 4 slices of cheese, and her utility function is given by $U_J = 4H + 3C$. Total endowments are 100 slices of ham and 200 slices of cheese.
- Draw the Edgeworth Box diagram for all possible exchanges in this situation. What is the contract curve for this exchange economy?
 - Suppose Smith's initial endowment is 40 slices of ham and 80 slices of cheese (Jones gets the remaining ham and cheese as her initial endowment). What mutually beneficial trades are possible in this economy and what utility levels will Smith and Jones enjoy from such trades?
 - Suppose that 20 slices of ham could be transferred without cost from Jones' to Smith's endowment. Now what mutually beneficial trades might occur and what utility levels would be experienced by Smith and Jones?
 - Suppose that Jones objects to the transfer of ham proposed in part c and states "I'd rather throw the ham away than give it to Smith." If Jones carries through on her threat, what mutually beneficial trades are now possible and what utility levels will be experienced by Smith and Jones?
 - Suppose that Smith expects the ham transfer from Jones and, through carelessness, allows 20 slices of her initial ham endowment to spoil. Assuming the transfer from Jones actually happens, now what mutually beneficial trades are possible, and what are the potential utility levels for Smith and Jones?
 - Suppose now that both of the adverse incentive effects mentioned in parts d and e occur simultaneously. What mutually beneficial trading opportunities remain, and what are the potential utility levels for Smith and Jones?



SOUTH-WESTERN
CENGAGE Learning™

NOT FOR SALE